

8270 Models 600 and 800



Planning, Configuration, and Operation
First Edition
July 1998

1st Edition (July 1998)

The following paragraph does not apply to the United Kingdom or any country where such provisions are inconsistent with local law: INTERNATIONAL BUSINESS MACHINES CORPORATION PROVIDES THIS PUBLICATION "AS IS" WITHOUT WARRANTY OF ANY KIND, EITHER EXPRESS OR IMPLIED, INCLUDING, BUT NOT LIMITED TO, THE IMPLIED WARRANTIES OF MERCHANTABILITY OR FITNESS FOR A PARTICULAR PURPOSE. Some states do not allow disclaimer of express or implied warranties in certain transactions, therefore, this statement may not apply to you.

This publication could include technical inaccuracies or typographical errors. Changes are periodically made to the information herein; these changes will be incorporated in new editions of the publication. IBM may make improvements and/or changes in the product(s) and/or program(s) described in this publication at any time.

It is possible that this publication may contain reference to, or information about, IBM products (machines and programs), programming, or services that are not announced in your country. Such references or information must not be construed to mean that IBM intends to announce such IBM products, programming, or services in your country.

Requests for technical information about IBM products should be made to your IBM Authorized Dealer or your IBM Marketing Representative.

A form for readers' comments appears at the back of this publication. If the form has been removed, address your comments to:

Department CGF
Design & Information Development
IBM Corporation
PO Box 12195
RESEARCH TRIANGLE PARK NC 27709-9990
USA

When you send information to IBM, you grant IBM a nonexclusive right to use or distribute the information in any way it believes appropriate without incurring any obligation to you.

© Copyright International Business Machines Corporation 1998. All rights reserved.

Note to U.S. Government Users — Documentation related to restricted rights — Use, duplication or disclosure is subject to restrictions set forth in GSA ADP Schedule Contract with IBM Corp.

Contents

Safety Information	xi
About This Manual	xix
How This Manual Is Organized	xix
Prerequisite Publication	xix
Related Publications	xix
Chapter 1. Physical Characteristics and Features	1-1
Product Features	1-2
Physical Characteristics	1-6
Power Supply	1-7
Processor Card	1-8
Universal Feature Cards	1-11
Dimensions and Weight	1-13
Power Requirements	1-13
Operating Environment	1-13
Functional Overview	1-14
Chapter 2. Network Planning and Installation Preparations	2-1
Preparations	2-1
Rules to Remember	2-1
Frame Length Limit	2-2
Cables and Distances between Devices	2-2
8270 Security	2-2
Sample Applications	2-4
Important Management Considerations	2-8
8270 Embedded RMON Feature	2-9
Using Planning Charts and Worksheets	2-11
Chapter 3. Configuration	3-1
Default Configuration Parameters	3-2
Preparing to Configure the 8270	3-6
Configuring a UFC	3-6
Navigating the Console Panels	3-7
Beginning the Console Session	3-8
Main Menu	3-9
Configuration Menu	3-10
Viewing Switch Information	3-11
Configuring Domains	3-13
Naming Domains	3-14
Setting Up IP Addresses	3-15
SNMP Network Management	3-17
Configuring SNMP	3-18
Creating Communities	3-19
Creating Trap Receivers	3-20
Transparent Bridge Spanning Tree	3-21
Port Parameters	3-23
Configuring Token-Ring Ports	3-25
Configuring Port Address Aging	3-28
Port Address Table Aging	3-29

Master Address Table Aging	3-30
Configuring Source-Routing Capabilities	3-31
Assigning or Changing LAN Segment Numbers	3-33
Internal Source-Route Bridge Configuration	3-34
Displaying LAN Segment Bridging Parameters	3-35
Changing LAN Segment Bridging Parameters	3-36
Source-Route Bridge Spanning Tree Configuration	3-38
Source-Route Bridge Path Cost	3-40
Source-Route Bridge (SRB) Manual Spanning Tree Parameters	3-41
Changing Address Filters and Port Security (Token-Ring Ports only)	3-42
Configuring Filters	3-43
Configuring Port Security Mode	3-45
Configuring TokenProbe (Token-Ring Ports only)	3-46
Configuring TokenPipe (Token-Ring Ports only)	3-48
Switching Mode Threshold (Token-Ring Ports only)	3-49
Password	3-51
Console Configuration	3-53
Serial Link Configuration	3-54
Telnet Configuration	3-55
Chapter 4. Monitoring the 8270	4-1
Viewing Module Information	4-2
Viewing the Master Address Table	4-3
Viewing the Master Route Descriptor Table	4-4
Viewing Switch Statistics	4-5
Viewing the Message Log Information	4-7
Viewing the Domain Address Table	4-8
Viewing the Domain Route Descriptor Table	4-9
Viewing Domain Statistics	4-10
Viewing Transparent Bridge Spanning Tree Statistics	4-11
Viewing Port Status	4-14
Viewing TokenPipe Status	4-16
Viewing the Port N Address Table	4-17
Viewing the Port N Route Descriptor Table	4-18
Viewing Port N Statistics	4-19
Viewing Port N Filters	4-23
Viewing Source-Route Bridge Spanning Tree Status	4-24
LAN Segment Selection List for Viewing SRB Statistics	4-26
Viewing Source-Route Bridge Statistics	4-27
Chapter 5. Resetting the 8270	5-1
Resetting with Diagnostics (Cold Boot)	5-1
Resetting without Diagnostics (Warm Boot)	5-1
Reset/Diagnostics	5-2
Reset Switch/Diagnostics	5-4
Chapter 6. Updating Software	6-1
Download the Diskette Image from the Internet	6-1
Download the Code into the 8270	6-1
Initiating a Download with the System Request Menu	6-2
Serial Port or TFTP Downloading with the Download Menu	6-3
BootP	6-5
Appendix A. Planning Charts and Worksheets	A-1

8270 Cabling Chart (1 of 2)	A-2
8270 Cabling Chart (2 of 2)	A-3
Switch Information Panel	A-4
Domain Name Panel	A-4
Domain Configuration Panel	A-5
IP Configuration Panel	A-6
SNMP Configuration Menu	A-7
SNMP—Community Strings Panel	A-7
SNMP—Trap Receivers Panel (1 of 2)	A-8
SNMP—Trap Receivers Panel (2 of 2)	A-9
Spanning Tree Panel	A-10
Spanning Tree—Port Priority and Path Cost Panel	A-11
Port Configuration Panel (1 of 2)	A-12
Port Configuration Panel (2 of 2)	A-13
Source-Route Configuration Panel	A-14
Internal Source-Route Bridge Configuration Menu	A-14
LAN Segment Bridging Parameters Panel	A-15
Source-Route Bridge Spanning Tree Configuration Panel	A-15
Source-Route Bridge Path Cost Panel	A-16
Source-Route Bridge Manual Spanning Tree Parameters Panel	A-16
TokenProbe Configuration Panel	A-17
TokenPipe Configuration Panel	A-17
Configure Filters Panel	A-18
Configure Port Security Mode Panel	A-19
Port Address Table Aging Panel	A-20
Master Address Table Aging Panel	A-21
Switching Mode Threshold	A-21
Password Panel	A-22
Serial Configuration Panel	A-22
Telnet Configuration Panel	A-22
Adapter Address to Physical Location	A-23
Physical Location to Adapter Address	A-24
Appendix B. Menus and Panels Index	B-1
Configuration Menus	B-1
Management and Statistics Panels	B-2
Appendix C. MAC Address Template	C-1
Appendix D. Internal Port Mapping	D-1
Glossary	X-1
Index	X-19

Figures

1-1.	The IBM 8270 Nways Token-Ring LAN Switch Model 800 and 600	1-1
1-2.	The 8270-600 Front View	1-6
1-3.	The 8270-800 Front View	1-6
1-4.	The 8270-800 Power Supply	1-7
1-5.	The 8270-800 Power Supply Faceplate	1-8
1-6.	The Token-Ring Processor Card Faceplate	1-9
2-1.	Typical Token-Ring LAN Segmentation	2-4
2-2.	A Simple Application of the 8270-600	2-4
2-3.	Typical Network without the 8270	2-5
2-4.	Relieving the Overstressed Backbone	2-6
2-5.	Using Multiple 8270s	2-7
2-6.	ATM Uplink Feature in a Network	2-7
2-7.	Using the Internal Source-Route Bridge Function	2-8
2-8.	Star-Wired Topology of Interconnected 8270s	2-9
3-1.	Copyright Panel	3-8
3-2.	Main Menu	3-9
3-3.	Configuration Menu	3-10
3-4.	Switch Information Panel	3-11
3-5.	Domain Configuration Panel	3-13
3-6.	Domain Names Panel	3-14
3-7.	IP Configuration Panel	3-15
3-8.	SNMP Configuration Menu	3-18
3-9.	Community Strings Panel	3-19
3-10.	Trap Receivers Panel	3-20
3-11.	Spanning Tree Panel	3-21
3-12.	Port Parameters Panel	3-23
3-13.	Token-Ring Port Configuration Panel	3-25
3-14.	Address Aging Menu	3-28
3-15.	Port Address Table Aging Panel	3-29
3-16.	Master Address Table Aging Panel	3-30
3-17.	Using Internal Source-Route Bridging and Source-Route Switching	3-31
3-18.	Simple External Source-Route Bridged Network	3-32
3-19.	Source-Route Configuration Panel	3-33
3-20.	Internal Source-Route Bridge Configuration Menu	3-34
3-21.	LAN Segment Bridging Parameters Panel	3-35
3-22.	Change LAN Segment Bridging Parameters Panel	3-36
3-23.	Source-Route Bridge Spanning Tree Configuration Panel (1 of 2)	3-38
3-24.	Source-Route Bridge Path Cost Panel	3-40
3-25.	Source-Route Bridge Manual Spanning Tree Parameters Panel	3-41
3-26.	MAC Filter & Port Security Menu	3-42
3-27.	Filter Configuration Panel	3-43
3-28.	Configure Port Security Mode Panel	3-45
3-29.	TokenProbe Configuration Panel	3-46
3-30.	TokenPipe Configuration Panel	3-48
3-31.	Switching Mode Threshold Panel	3-49
3-32.	Password Panel	3-51
3-33.	Console Configuration Menu	3-53
3-34.	Serial Link Configuration Panel	3-54
3-35.	Telnet Configuration Panel	3-55
3-36.	Telnet Sessions Panel	3-56

4-1.	Status/Statistics Menu	4-1
4-2.	Module Information Panel	4-2
4-3.	Master Address Table Panel	4-3
4-4.	Master Route Descriptor Table Panel	4-4
4-5.	Switch Statistics Panel	4-5
4-6.	Message Log Information Panel	4-7
4-7.	Domain Address Table Panel	4-8
4-8.	Domain Route Descriptor Table Panel	4-9
4-9.	Domain Statistics Panel	4-10
4-10.	Transparent Bridge Spanning Tree Information Panel	4-11
4-11.	Port Status Panel	4-14
4-12.	TokenPipe Status Panel	4-16
4-13.	Port N Address Table Panel	4-17
4-14.	Port N Route Descriptor Table Panel	4-18
4-15.	Port N Statistics Panel (1 of 2)	4-19
4-16.	Port N Statistics Panel (2 of 2)	4-21
4-17.	Port N Filters Panel	4-23
4-18.	Source-Route Bridge Spanning Tree Status Panel	4-24
4-19.	Source-Route Bridge LAN Segment Selection Panel	4-26
4-20.	Source-Route Bridge Statistics Panel	4-27
5-1.	Reset/Diagnostics Panel	5-2
5-2.	Diagnostic Test Results Panel	5-3
5-3.	Messages during Diagnostics	5-5
6-1.	System Request Menu	6-2
6-2.	Download Menu	6-3
6-3.	TFTP Download Panel	6-5
6-4.	Example of a BOOTPTAB File	6-7

Tables

1-1.	Power Supply Status LEDs (8270-800 Only)	1-8
1-2.	Status LEDs	1-9
1-3.	Token-Ring Port LEDs	1-12
1-4.	Dimensions and Weight	1-13
1-5.	Operating Environment	1-13
2-1.	Token-Ring RMON Groups	2-10
3-1.	MIBs Implemented in the 8270 SNMP Agent	3-17

Safety Information

 **Danger:** Before you begin to install this product, read the safety information in *Caution: Safety Information—Read This First*, SD21-0030. This booklet describes safe procedures for cabling and plugging in electrical equipment.

 **Danger:** No user serviceable parts inside product. Refer service to qualified personnel.

 **Varning — livsfara:** Innan du börjar installera den här produkten bör du läsa säkerhetsinformationen i dokumentet *Varning: Säkerhetsföreskrifter— Läs detta först*, SD21-0030. Där beskrivs hur du på ett säkert sätt ansluter elektrisk utrustning.

 **WARNING:** Service ska endast utföras av utbildad servicepersonal.

 **Fare:** Før du begynner å installere dette produktet, må du lese sikkerhetsinformasjonen i *Advarsel: Sikkerhetsinformasjon — Les dette først*, SD21-0030 som beskriver sikkerhetsrutinene for kabling og tilkobling av elektrisk utstyr.

 **Fare:** Inneholder ingen deler som kan repareres av brukeren. Overlat service til kvalifisert personell.

 **Fare!** Før du installerer dette produkt, skal du læse sikkerhedsforskrifterne i *NB: Sikkerhedsforskrifter—Læs dette først* SD21-0030. Vejledningen beskriver den fremgangsmåde, du skal bruge ved tilslutning af kabler og udstyr.

 **Fare!** Indvendigt eftersyn af dette produkt må kun foretages af servicepersonale.

 **Gevaar:** Voordat u begint met de installatie van dit produkt, moet u eerst de veiligheidsinstructies lezen in de brochure *PAS OP! Veiligheidsinstructies—Lees dit eerst*, SD21-0030. Hierin wordt beschreven hoe u elektrische apparatuur op een veilige manier moet bekabelen en aansluiten.

 **GEVAAR:** Dit produkt bevat geen onderdelen die door de gebruiker kunnen worden hersteld. Voor herstellingen moet u een beroep doen op gespecialiseerd onderhoudspersoneel.

 **Gevaar** Voordat u begint met het installeren van dit produkt, dient u eerst de veiligheidsrichtlijnen te lezen die zijn vermeld in de publikatie *Caution: Safety Information - Read This First*, SD21-0030. In dit boekje vindt u veilige procedures voor het aansluiten van elektrische apparatuur.

 **GEVAAR:** In dit product bevinden zich geen onderdelen die door de gebruiker kunnen worden onderhouden. Laat onderhoud over aan bevoegd personeel.

 **Vorsicht:** Bevor mit der Installation des Produktes begonnen wird, die Sicherheitshinweise in *Achtung: Sicherheitsinformationen—Bitte zuerst lesen*, IBM Form SD21-0030. Diese Veröffentlichung beschreibt die Sicherheitsvorkehrungen für das Verkabeln und Anschließen elektrischer Geräte.

 **Vorsicht:** Keine vom Benutzer zu wartenden Teile vorhanden. Instandhaltungsarbeiten dürfen nur von Fachpersonal durchgeführt werden.





危険： 導入作業を開始する前に、安全に関する小冊子SD21-0030 の「最初にお読みください」(Read This First)の項をお読みください。この小冊子は、電気機器の安全な配線と接続の手順について説明しています。





危険

製品内部にはユーザーが保守できる部品はありません。保守については訓練されたサービス技術員に問い合わせてください。

 **Danger :** Avant d'installer le présent produit, consultez le livret *Attention : Informations pour la sécurité — Lisez-moi d'abord*, SD21-0030, qui décrit les procédures à respecter pour effectuer les opérations de câblage et brancher les équipements électriques en toute sécurité.

 **Danger:** Le produit ne contient pas de pièces réparables par l'utilisateur. Adressez-vous à du personnel qualifié pour les réparations.

 **Danger:** Avant de procéder à l'installation de ce produit, lisez d'abord les consignes de sécurité dans la brochure *ATTENTION: Consignes de sécurité—A lire au préalable*, SD21-0030. Cette brochure décrit les procédures pour câbler et connecter les appareils électriques en toute sécurité.

 **Danger:** Ce produit ne contient pas d'éléments susceptibles d'être entretenus par l'utilisateur. Faites appel à un technicien qualifié.

 **Pericolo:** prima di iniziare l'installazione di questo prodotto, leggere le informazioni relative alla sicurezza riportate nell'opuscolo *Attenzione: Informazioni di sicurezza — Prime informazioni da leggere* in cui sono descritte le procedure per il cablaggio ed il collegamento di apparecchiature elettriche.

 **Pericolo:** Questo prodotto non contiene parti sostituibili dall'utente. Se occorre, richiedere assistenza tecnica a personale specializzato.

 **Perigo:** Antes de iniciar a instalação deste produto, leia as informações de segurança *Cuidado: Informações de Segurança — Leia Primeiro*, SD21-0030. Este documento descreve como efectuar, de um modo seguro, as ligações eléctricas dos equipamentos.

 **Perigo:** Nenhum dos componentes internos pode ser reparado pelo cliente. Para qualquer reparação, chame sempre um técnico especializado.

 **Peligro:** Antes de empezar a instalar este producto, lea la información de seguridad en *Atención: Información de Seguridad — Lea Esto Primero*, SD21-0030. Este documento describe los procedimientos de seguridad para cablear y enchufar equipos eléctricos.

 **Peligro:** Dentro del producto no hay piezas a las que el usuario pueda prestar servicio técnico. Ceda el servicio a personal cualificado.

 **Perigo:** Antes de começar a instalar este produto, leia as informações de segurança contidas em *Cuidado: Informações Sobre Segurança—Leia Isto Primeiro*, SD21-0030. Esse folheto descreve procedimentos de segurança para a instalação de cabos e conexões em equipamentos elétricos.

 **Perigo:** Dentro deste produto não existem peças que possam ser manuseadas por parte do usuário. Qualquer serviço dentro deste produto deverá ser executado por pessoa autorizada e qualificada.

 **VAARA:** Ennen kuin aloitat tämän tuotteen asennuksen, lue julkaisussa *Varoitus: Turvaohjeet—Lue tämä ensin*, SD21-0030, olevat turvaohjeet. Tässä kirjasessa on ohjeet siitä, miten sähkölaitteet kaapeloidaan ja kytketään turvallisesti.

 **VAARA:** Tuotteessa ei ole käyttäjän huollettavaksi tarkoitettuja osia. Tuotteen saa huoltaa vain ammattitaitoinen huoltoedustaja.



위험: 이 제품을 설치하기 전에 반드시
"주의: 안전 정보-시작하기 전에"
(SD21-0030-02)에 있는 안전 정보를
읽으십시오.



위험

사용자가 제품의 내부를 절대 수리하지 마십시오.
면허를 소지한 기술자에게 서비스를 의뢰 하십시오.



危險：安裝本產品之前，請先閱讀
"Caution: Safety Information--Read
This First" SD21-0030 手冊中所提
供的安全注意事項。這本手冊將會說明
使用電器設備的纜線及電源的安全程序。



危險：
在产品内，没有用户可检修的部件。请把检修交给合格的人员。



Uwaga:
Przed rozpoczęciem instalacji produktu należy zapoznać się z instrukcją:
"Caution: Safety Information - Read This First", SD21-0030.
Zawiera ona warunki bezpieczeństwa przy podłączeniu do sieci elektrycznej
i eksploatacji.



NIEBEZPIECZEŃSTWO:
Nie otwierać.
Serwis wyłącznie przez wykwalifikowany personel.



Upozornění: než zahájíte instalaci tohoto produktu, přečtěte si
nejprve bezpečnostní informace v pokynech „Bezpečnostní
informace“ č. 21-0030. Tato brožurka popisuje bezpečnostní
opatření pro kabeláž a zapojení elektrického zařízení.



NEBEZPEČÍ:

Uvnitř výrobku nejsou žádné díly určené k opravě uživatelem.
Opravu svěřte kvalifikované osobě.



Vigyázat: Mielőtt megkezdi a berendezés üzembe helyezését, olvassa el a *Caution: Safety Information— Read This First*, SD21-0030 könyvecskében leírt biztonsági információkat. Ez a könyv leírja, milyen biztonsági intézkedéseket kell megtenni az elektromos berendezés huzalozásakor illetve csatlakoztatásakor.



Magyarország

VIGYÁZAT, VESZÉLY.

A termék a felhasználó által nem szervizelhető. Szervizigényével forduljon szakemberhez.



Pozor: Preden začnete z instalacijo tega produkta preberite poglavje: "Opozorilo: Informacije o varnem rokovanju-preberi pred uporabo," SD21-0030. To poglavje opisuje pravilne postopke za kabliiranje,



OPOZORILO: Proizvod ne vsebuje delov, katere sme servisirati uporabnik. Servis zaupajte kvalificiranemu osebj.



ОСТОРОЖНО: Прежде чем устанавливать этот продукт, прочтите Инструкцию по технике безопасности в документе "Внимание: Инструкция по технике безопасности -- Прочсть в первую очередь", SD21-0030. В этой брошюре описаны безопасные способы каблирования и подключения электрического оборудования.



ОПАСНО:

Внутри устройства нет никаких деталей, подлежащих обслуживанию или регулировке пользователем. Обслуживание производится только квалифицированным специалистом.



Opasnost: Prije nego što počnete sa instalacijom produkta, pročitajte naputak o pravilima o sigurnom rukovanju u Upozorenje: Pravila o sigurnom rukovanju - Prvo pročitaj ovo, SD21-0030. Ovaj priručnik opisuje sigurnosne postupke za priključivanje kabela i priključivanje na električno napajanje.



Opasnost: Ne sadrži dijelove popravljive od strane korisnika. Održavanje prepustiti ovlaštenom osoblju.



Nebezpečnosť: Pred inštaláciou výrobku si prečítajte bezpečnostné predpisy v Výstraha: Bezpečnostné predpisy - Prečítaj ako prvé, SD21 0030. V tejto brožúrke sú opísané bezpečnostné postupy pre pripojenie elektrických zariadení.



Nebezpečnosť: Nedotýkajte sa vnútorných častí zariadenia. Kontaktujte kvalifikované osoby v servise.



ОПАСНОСТ
Пред да почнете да го инсталирате овој продукт, прочитајте ја информацијата за безбедност:
"Предупредување: Информација за безбедност: Прочитајте го прво ова", SD21-0030.
Оваа брошура опишува безбедносни процедури за каблирање и вклучување на електрична опрема.



ОПАСНОСТ

Во производот нема делови кои може да се сервисираат од корисникот. Препуштете го сервисирањето на квалификувани лица.



危險：

開始安裝此產品之前，請先閱讀安全資訊。

注意：

請先閱讀 - 安全資訊 SD21-0030

此冊子說明插接電器設備之電纜線的安全程序。



危險：

在產品內無適合使用者自行處理的零件，請洽專業人替您服務。



Κίνδυνος: Πριν ξεκινήσετε την εγκατάσταση αυτού του προϊόντος, διαβάστε τις πληροφορίες ασφάλειας στο φυλλάδιο *Caution: Safety Information-Read this first, SD21-0030*. Στο φυλλάδιο αυτό περιγράφονται οι ασφαλείς διαδικασίες για την καλωδίωση των ηλεκτρικών συσκευών και τη σύνδεσή τους στην πρίζα.

About This Manual

This manual explains how to plan for, configure, and use the IBM 8270 Nways Token-Ring LAN Switch Models 600 and 800 (hereafter referred to as the *8270*). 8270 refers to both Model 800 (8270-800) and Model 600 (8270-600). 8270-800 refers to the Model 800 only, and 8270-600 refers to the Model 600 only. The 8270 consists of a base unit, a Token-Ring Processor Card, and at least one Universal Feature Card (UFC) installed. The 8270-800 can have either one or two power supplies.

The 8270 comes preconfigured for Plug and Play capability. You might not have to configure the switch for it to operate in your network. However, should you choose to change default settings, this manual explains how to do so.

How This Manual Is Organized

- Chapter 1, “Physical Characteristics and Features” describes the 8270. It also provides a brief functional overview.
- Chapter 2, “Network Planning and Installation Preparations” explains how to plan for the installation and configuration of an 8270, and provides sample scenarios.
- Chapter 3, “Configuration” provides the default configuration parameters, definitions of those parameters, and instructions for changing the settings. The chapter is organized from domain-specific settings to port-specific settings.
- Chapter 4, “Monitoring the 8270” provides procedures for viewing switch status or statistics. The chapter is arranged from switch-specific parameters, to domain parameters, to port-specific parameters.
- Chapter 5, “Resetting the 8270” explains how to reset the 8270 and run diagnostic tests.
- Chapter 6, “Updating Software” describes procedures for downloading new code.
- Appendix A, “Planning Charts and Worksheets” provides charts and worksheets that can be used for planning and configuring your 8270s.
- Appendix B, “Menus and Panels Index” provides a list of the names of all the menus and panels on the 8270 management and configuration tool.
- Appendix C, “MAC Address Template” defines how the 96 MAC addresses assigned to the switch are allocated.
- Appendix D, “Internal Port Mapping” lists internal port numbers.

Prerequisite Publication

Caution: Safety Information—Read This First, SD21-0030.

Related Publications

- *Token-Ring Network, Introduction and Planning Guide*, GA27-3677
- *IBM LAN Bridge and Switch Summary*, SG24-5000
- *2-Port Fiber and 4-Port UTP/STP Token-Ring Enhanced Universal Feature Cards Planning and Installation Guide*, GA27-4168
- *8270 Installation and Service Guide*—available on this CD-ROM

- *ATM 155-Mbps MM Fiber Universal Feature Card Planning and Installation Guide*, GA27-4156 —available on this CD-ROM
- *MSS Client UFC Planning and Installation Guide*, GA27-4170 —available on this CD-ROM
- *MSS Domain Client UFC Planning and Installation Guide* , GA27-4171 —available on this CD-ROM

Chapter 1. Physical Characteristics and Features

The IBM 8270 Nways Token-Ring LAN Switch is a member of and fully compatible with the 8270 family of LAN switches, which includes the 8272 Nways Token-Ring LAN Switch, Models 108 and 216, and the 8272 LAN Switch Modules, Feature Codes 5208, 5308, 6208 and 6308, for the IBM 8260 Nways Multiprotocol Switching Hub and 8265 Nways ATM Switch.

The 8270 provides high-speed forwarding of Token-Ring frames among the shared or dedicated Token-Ring segments attached to each of the 8270 ports. The 8270 creates multiple, concurrent paths among the connected segments, each supporting the full, 16-Mbps Token-Ring bandwidth. The 8270 also supports ATM uplink connections.

The 8270 forwards Token-Ring frames among multiple, shared or dedicated, Token-Ring LAN segments. Using a frame-forwarding technique similar to that of a multiport, Token-Ring transparent bridge, the 8270 uses both Token-Ring MAC addresses and source-route descriptors to forward Token-Ring frames from one of its ports to another.

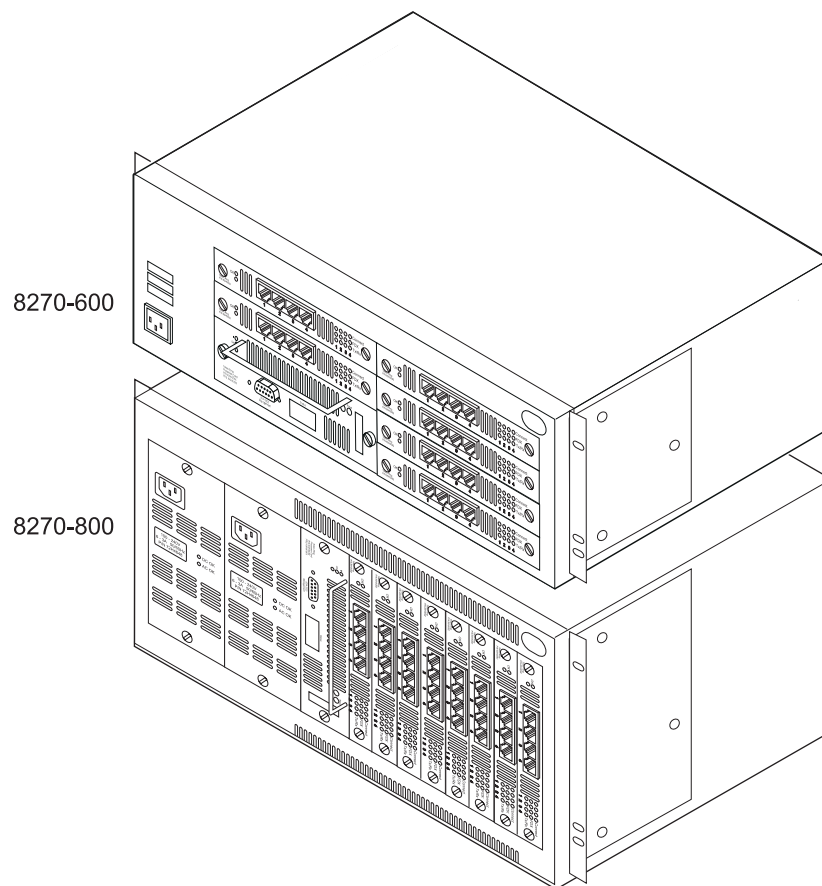

Figure 1-1. The IBM 8270 Nways Token-Ring LAN Switch Model 800 and 600

The 8270 is a rack- or surface-mount chassis that provides slots for one Token-Ring Processor Card and up to six (for the 8270-600) or eight (for the

8270-800) Universal Feature Cards (UFCs). In addition to supporting more UFCs, the 8270-800 can have redundant, load-sharing power supplies and redundant cooling fans. The 8270 can connect to Token-Ring and ATM networks. All LAN ports on the 8270 are provided by UFCs. At least one UFC must be installed in order to have a functional unit. The following UFCs can be installed in the 8270:

- 4-Port Token-Ring/Enhanced UTP/STP UFC
- 2-Port Token-Ring/Enhanced Fiber UFC
- ATM 155-Mbps Multimode Fiber/Token-Ring II UFC
- MSS Client Single Mode Fiber UFC
- MSS Client Multimode Fiber UFC
- MSS Domain Client UFC

Product Features

The 8270 comes preset with the appropriate default settings for Plug and Play capability. In a simple network configuration, the 8270 can be used with the factory default settings. The 8270 includes the following features:

IEEE 802.5 compliance

Full compliance with the IEEE 802.5 Token-Ring Standard for both classic and emerging Dedicated Token-Ring Standard. Supports token-ring frames up to 4540 bytes and priority messaging.

Virtual switching

The virtual switch feature allows you to divide the switch into as many as sixteen, non-overlapping broadcast domains to help manage traffic and isolate some users from certain network resources. Each domain has its own IP address. Packets are forwarded between ports in the same domain only.

Source-Route Switching

The 8270 forwards frames based on both the destination MAC address and the source-route descriptors. Frames that are destined for a target station more than one bridge hop away from a switch are forwarded based on the source-route descriptors only. Frames destined for stations that can be reached without passing through an intervening source-route bridge are forwarded based on the 6-byte destination MAC address.

The portion of each route descriptor that designates the "next hop" will appear in both the port and master address tables. The source-route descriptors and MAC addresses are automatically learned by the switch through observation of normal traffic flow. Source-Route Switching (SRS) offers the following advantages:

- The port and master address tables require fewer entries, since the MAC addresses of stations more than one bridge hop away are not required for frame forwarding
- Source-route networks can include redundant or parallel paths between the source and destination stations
- Duplicate MAC addresses can be supported in a switched environment when the duplicate addresses are associated with unique ring segment numbers

Source-Route Bridging

To further enhance the advantages of Source-Route Switching, the 8270 provides a built-in source-route bridge function. Source-Route Bridging

switches frames among Token-Ring segments with different LAN IDs (also called *ring numbers*). This capability allows any combination of 8270 domains to be interconnected internally by a multiport source-route bridge.

In addition, Source-Route Bridging dynamically updates the maximum frame size for each route, eliminating the need to configure the frame size at every work station in the network.

Variable switching modes

The 8270 provides the following switching modes:

- *Cut-Through mode*, which provides the benefits of low-latency, high-speed switching.
- *Store-and-Forward mode*, which provides more error isolation between segments.
- *Adaptive mode*, which takes advantage of the benefits of the preceding two modes. You can configure the 8270 to alternate automatically between Cut-Through and Store-and-Forward modes based on your specified, soft-error thresholds.

MAC addresses

A factory-assigned range of 96 MAC addresses.

10 000 filter table entries (MAC addresses and route descriptors)

The 8270 supports a maximum of 1790 filter table entries per port, but no more than 10 000 for each 8270. The filter tables include both MAC address and source-route descriptor entries.

MAC address filtering

MAC address filtering and port security enable the 8270 to control traffic on the network by allowing up to 100 source or destination MAC addresses to be selectively filtered at the port of entry into the 8270.

User-set MAC address aging parameters

The address tables have user-configurable aging parameters that you can set by port or for the entire 8270. You can configure the 8270 to clear space in the address tables when a configurable threshold is exceeded.

Ease of use and adaptability

The 8270 provides

- Automatic sensing and configuration of the Token-Ring ports.
- Adaptive switching mode.
- Easy installation.

TokenPipes

You can configure ports in connected 8270s to create two to four parallel, 16-Mbps links. This increases capacity on a single connection between 8270s to support up to 64 Mbps half-duplex (HDX) or 128 Mbps full-duplex (FDX) by using TokenPipes.

Management

Console management via the serial port, connected directly or through a modem, or an in-band TCP/IP session using Telnet or an SNMP manager.

SNMP

Currently the IBM 8270 LAN Switches provide support for an extensive list of standard MIBs in addition to a common private MIB.

Spanning Tree

As part of the Spanning Tree function, the 8270 allows you to set specific port cost and port priority parameters. When the Spanning Tree reconfigures itself, it selects forwarding ports based on the port cost. For port priority, the port with the lowest priority value has the highest priority and will forward Spanning Tree frames.

Note that the 8270 provides two Spanning Tree functions – one for domains not enabled for source-route bridging and one for source-route bridged domains. The parameter settings are independent for each of the two Spanning Tree functions.

Statistics

The 8270 keeps statistics by port, by connected station, and for the Token-Ring processor.

TokenProbe feature

You can configure any of the Token-Ring ports as the TokenProbe port. This port then monitors any of the other Token-Ring ports on that switch so that a network analyzer can trace port activity.

Easy software upgrades

You can download software upgrades through the console port or TFTP.

You can initiate a download command from the console menu or the command can result from corrupted flash detection during the POST. When this command is initiated, the 8270 accepts the downloaded file using the Xmodem file transfer protocol in a terminal emulator.

Console interface

Provides a console interface through the following media:

- Direct link into serial port.
- Link to serial port using a modem.
- Telnet session.

You can also use SNMP management for a switch interface.

Mounting options

Can be rack or surface mounted.

RMON

The 8270 has an embedded RMON feature. It supports the following Token-Ring RMON groups:

- Token-Ring statistics
- History control
- Token-Ring history
- Alarms
- Events

Security

The 8270 security features include:

- Passwords for configuration and monitoring of the switch (see “Password” on page 3-51)

- Filtering options to block specified traffic from traversing the switch (see “Configuring Filters” on page 3-43)
- Port security options to allow only specified traffic to traverse the switch (see “Configuring Port Security Mode” on page 3-45)
- SNMP read/write protection based on community name (see “Creating Communities” on page 3-19)

Physical Characteristics

The 8270 consists of a base unit, a Token-Ring Processor Card, and at least one Universal Feature Card (UFC). The 8270-800 can have either one or two power supplies.

The front views of the 8270-600 and 8270-800 are illustrated in Figure 1-2 and Figure 1-3 respectively. Following the illustrations is a description of each of the plug-in modules and UFCs. The connectors, indicators, and switches for each module are also discussed.

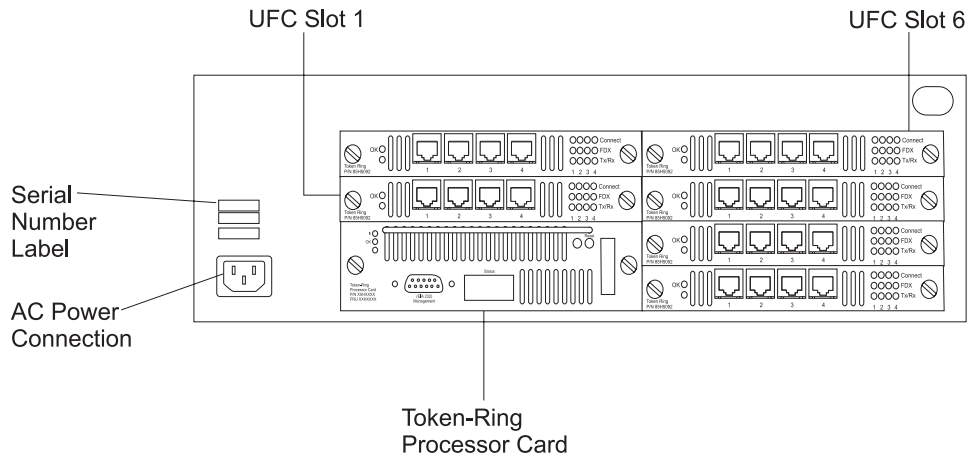

Figure 1-2. The 8270-600 Front View

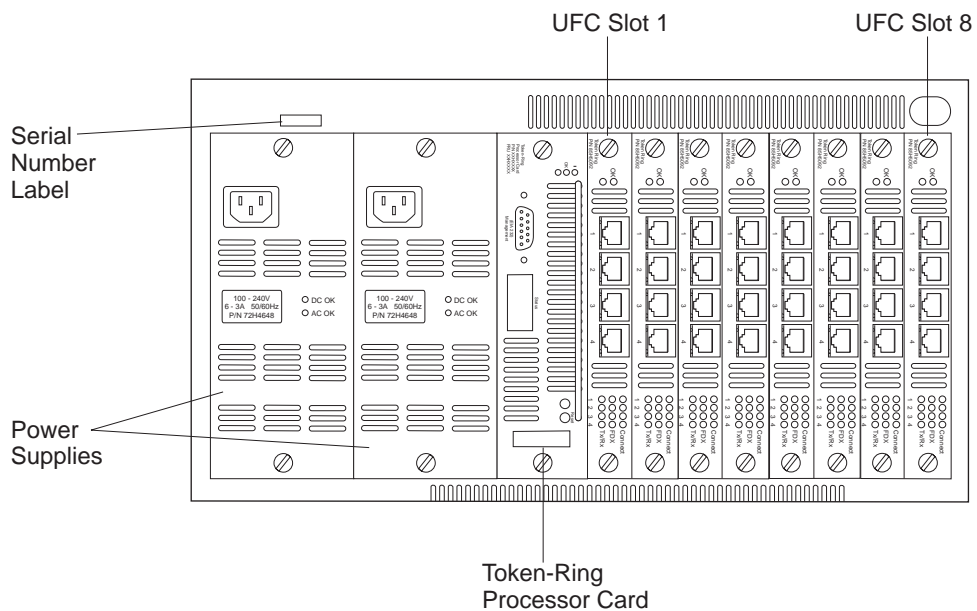

Figure 1-3. The 8270-800 Front View

Power Supply

The 8270-600 has a single internal power supply, while the 8270-800 provides the capability to have two power supplies. Both the 8270-600 and the 8270-800 can operate on input line voltage from 100—240 volts.

8270-800 Power Supply: The 8270-800 provides two slots for power supplies. These are the two leftmost slots in the chassis. (see Figure 1-3 on page 1-6). At least one power supply must be installed. The 8270-800 is shipped with a single power supply installed in the right slot. The left slot is available for installation of an optional, redundant power supply.

If two power supplies are installed, they share the power load. In the event of a failure by either supply, the good power supply automatically maintains power for the entire 8270-800. Operation of the 8270-800 is not disrupted.

The 8270-800 power supplies are *hot-pluggable*. That means they can be removed and installed while the 8270-800 is powered up. When two power supplies are installed, hot-plugging allows a failed power supply to be replaced without disrupting operation of the switch. Both power supplies must have a line cord connected to ac power.

Figure 1-4 illustrates the 8270-800 power supply.

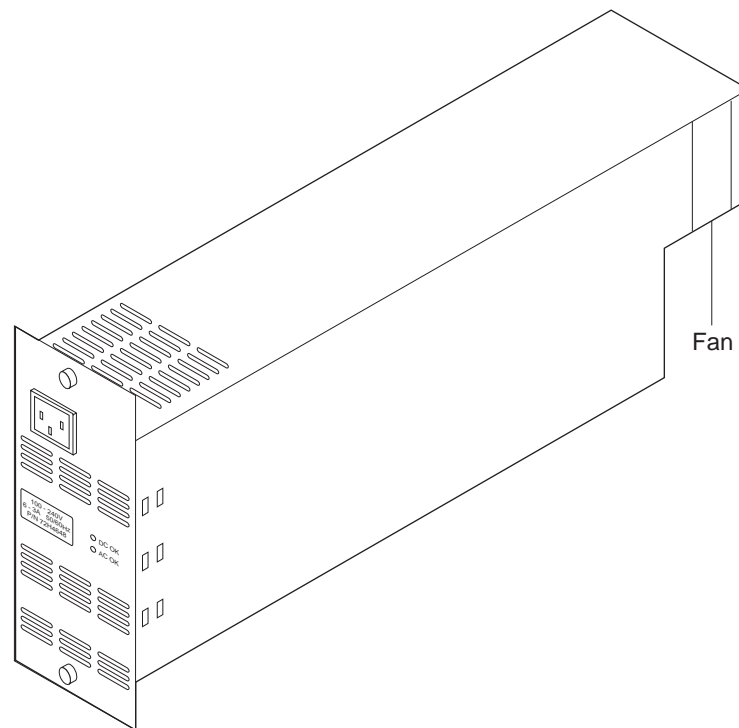

Figure 1-4. The 8270-800 Power Supply

The integrated cooling fan for the power supply is located at the rear of the module. Details of the power supply faceplate are shown in Figure 1-5 on page 1-8.

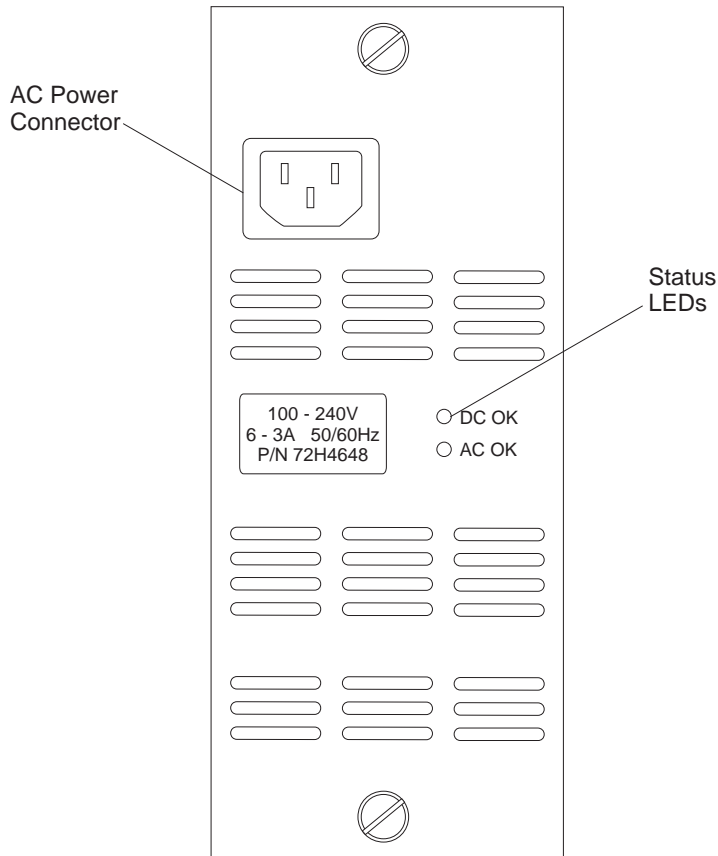

Figure 1-5. The 8270-800 Power Supply Faceplate

One connector and two LEDs are on the power supply faceplate. The connector is for a standard three-prong power cord that connects to 120/220 V AC at 50/60 Hz line frequency. The LEDs indicate the status of the ac power input (AC OK) and the DC power output (DC OK). See Table 1-1.

Table 1-1. Power Supply Status LEDs (8270-800 Only)

LED	State	Meaning
DC OK	On	DC power output is OK.
	Off	DC power output is not OK.
AC OK	On	AC power input is OK.
	Off	AC power input is not OK.

Processor Card

In the 8270-600, the Token-Ring Processor Card comes pre-installed in the lower left slot. As part of the installation described in the *8270 Models 600 and 800 Installation and Service Guide*, you must install the Token-Ring Processor Card in the 8270-800 in the third slot from the left. Though similar in function, the cards are not interchangeable. The Token-Ring Processor Card faceplate has three status LEDs, one communication port, one 4-character alphanumeric display and two push buttons. See Figure 1-6 on page 1-9. Each of these items is discussed in detail in the following sections.

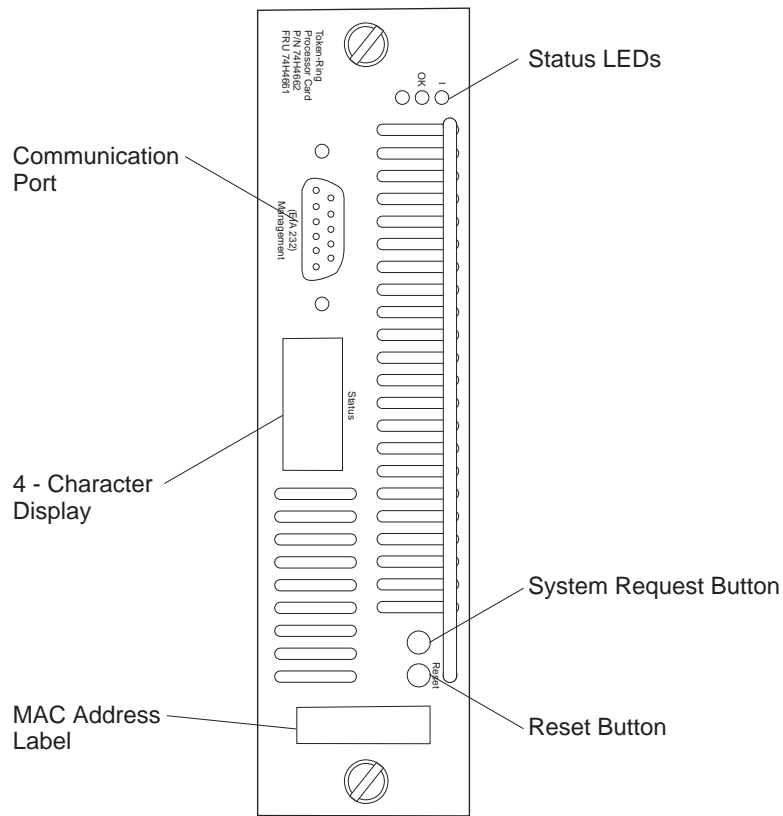

Figure 1-6. The Token-Ring Processor Card Faceplate

Status LEDs

The Token-Ring Processor card has three status LEDs. See Figure 1-6 for the locations of the LEDs.

Table 1-2. Status LEDs

Function (color)	Label	State	Meaning
Power (green)		On	The Token-Ring Processor Card is receiving power from the 8270 backplane.
		Off	The Token-Ring Processor Card is not receiving power from the 8270 backplane.
OK (green)	OK	On	The 8270 is working correctly.
		Off	The 8270 is not working correctly.
		Blinking	Diagnostics are in progress.
Fault (amber)	none	On	A diagnostic failure has occurred. The Token-Ring Processor Card is bad and should be replaced.
		Off	The 8270 is working correctly.
		Blinking	Diagnostics are in progress.

Status Display

The 4-character alphanumeric display provides additional status information concerning the state of the 8270. This includes the power supplies, the Token-Ring Processor Card, any UFCs, and any cooling fans. The messages are decoded as follows:

- Power-On Self Test messages

When Power-On Self Test is running, the first display character is T, followed by a 3-digit numeric code identifying the test in progress. If the test fails, the T character changes to E and the test stops.

- OK

This message appears for 2 minutes after a successful Power-On Self Test to indicate that the 8270 is working correctly.

- Non-test messages

- The first 2 display characters identify the system component:

F1 Fan 1

F2 Fan 2 (8270-800 only)

P1 Power supply 1

P2 Power supply 2 (8270-800 only)

PC Processor card

Sx UFC in slot x

!A Fuses 3 and 4 (8270-800 only)

Note: Fuses 3 and 4 control power to the 8270-800 Token-Ring Processor Card. If either fuse 3 or fuse 4 fails, the Token-Ring Processor Card becomes inoperative and cannot display status messages.

!B Fuses 1 and 2 (8270-800 only)

!C Fuses 7 and 8 (8270-800 only)

!D Fuse 6 (8270-800 only)

- The third display character indicates the required action:

H Hardware failure. Replace the component identified by the first 2 characters in the message.

Note: Replacement of fans, fuses, and the 8270-600 power supply can be done by qualified service personnel only.

C Software failure. Download new software and reconfigure.

C1 - Boot image

C2 - Main image

X UFC is not installed in a valid slot. Move the UFC to a valid slot.

? The failure cannot be isolated to a specific component. Refer to troubleshooting procedures found in the *8270 Installation and Service Guide*.

EIA 232 Port

This nine-pin, male, management port functions as a DTE port.

With this port you can attach a VT100 terminal or VT100 terminal emulator to use when customizing the switch's configuration, monitoring switch activity and switch status, testing the switch, or downloading software (see Chapter 6, "Updating Software"). Console access can be either local, by direct attachment to the EIA 232 port, or remote, through a modem connection.

When enabled, the EIA 232 port automatically detects the baud rate of the terminal to which it is attached.

Reset Button

The Reset button resets the hardware and software and clears all tables and memory, including the address tables. Pressing the Reset button does not clear the user-set configuration parameters; those values are stored in nonvolatile random access memory (NVRAM). For more information about the Reset button, see Chapter 5, "Resetting the 8270" on page 5-1.

System Request Button

The System Request button is located next to the Reset button. It is unlabeled and is recessed to prevent unintentional activation. Pressing this button causes the System Request Menu to appear on the console device attached to the EIA 232 port. See "Initiating a Download with the System Request Menu" on page 6-2 for more information.

Universal Feature Cards

The 8270 contains UFC slots (see Figure 1-2 on page 1-6 or Figure 1-3 on page 1-6) that accommodate optional, field-installable UFCs to provide network connections. Currently available UFCs provide the following types of connections:

- Token-Ring UTP/STP
- Token-Ring optical fiber
- ATM network

Token-Ring Ports

Depending upon the type and quantity of UFCs installed, the 8270-800 can provide up to 30 Token-Ring ports, the 8270-600 can support up to 24 ports. This configuration requires 4-port UTP/STP UFCs. The 4-port UFC provides shielded RJ-45 connectors for the Token-Ring connections.

Note: (8270-800 Only) Ports 3 and 4 on UFC slot 1 are not available for use. When a 4-port UFC is installed in slot 1, the invalid slot message (X) appears in the Status display. Even though the invalid slot message is displayed, the 4-port UFC will operate correctly for ports 1 and 2.

Token-ring ports allow HDX or FDX connections to other switches, hubs, or end nodes. The ports can be connected to the IBM Cabling System via 150-ohm, STP, or 100-ohm or 120-ohm twisted-pair (shielded or unshielded).

You can also use optical fiber Token-Ring ports provided by the 2-port Fiber Token-Ring UFC. These ports are compatible with RI/RO ports and make connection to the network through ST**-compatible optical receptacles and

multimode optical fiber cables. Since this UFC has only 2 ports, it is valid for installation in slot 1 of the 8270-800.

The 8270 automatically senses the following types of Token-Ring connection on each port:

- Shared-media segment via a Token-Ring concentrator
- Another Token-Ring switch
- 4-Mbps or 16-Mbps, Token-Ring segment
- Dedicated- or shared-media segment, directly to a Token-Ring LAN station
- HDX mode
- FDX mode

The 8270 automatically configures (requiring no operator action) each port to operate at the highest level of capability possible. No special crossover cables are required for Token-Ring stations on dedicated-media segments or for switch-to-switch connections. These connections use the same cabling used to connect the 8270 port to shared-media segments. You can configure the 8270 to override this auto-sense and auto-configure capability through the console configurator.

UFC Status LEDs

8270 UFCs have OK and Fault (unlabeled) status LEDs. The meaning of these LEDs is similar to those on the Token-Ring Processor Card. Refer to the documentation provided with the UFC for details regarding these LEDs.

UFC Port LEDs

In addition to the status indicators, UFCs have LEDs that show the status of the ports provided by the UFC. Table 1-3 provides the meaning of the port LEDs on the Token-Ring UFCs.

Table 1-3. Token-Ring Port LEDs

LED	Position	State	Meaning
Connect	Top	On	Connected.
		Off	Disabled or faulty port, if the UFC Fault LED is on.
		Blinking	Attempting to connect.
FDX	Middle	On	The port is set to FDX mode.
		Off	The port is set to HDX mode.
Tx/Rx	Bottom	On	Data is being transferred or received by the port.
		Off	Data is not being transferred or received by the port.

Refer to the documentation provided with the UFC for details regarding other port LEDs.

Dimensions and Weight

Table 1-4 provides the dimensions and weight of the 8270-800.

Table 1-4. Dimensions and Weight

	8270-600	8270-800
Width	440 mm (17.3 in.)	440 mm (17.3 in.)
Depth	305 mm (12.0 in.)	356 mm (14.0 in.)
Height	133 mm (5.2 in.)	222 mm (8.7 in.)
Weight (configuration dependant)	7 to 10 kg (16 to 21 lb)	17 to 23 kg (37.5 to 50.7 lb)

Power Requirements

The 8270 auto-ranging power supplies operates on nominal line voltages in the range of 100 to 127 or 200 to 240 V ac, and 50 or 60 Hz. Power cord information is included with the 8270 ordering instructions for your country.

Operating Environment

Table 1-5. Operating Environment

Characteristic	Typical Configuration	Maximum Configuration
Temperature	10° to 40°C (50° to 104°F)	Same as typical
Relative humidity	8% to 80%	Same as typical
Maximum wet-bulb temperature	27°C (81°F)	Same as typical
Caloric value (8270-600)	130 Kcal/hr (500 BTU/hr)	170 Kcal/hr (680 BTU/hr)
Caloric value (8270-800)	180 Kcal/hr (700 BTU/hr)	360 Kcal/hr (1400 BTU/hr)
Electrical power (8270-600)	0.15 KW	0.2 KW
Electrical power (8270-800)	0.25 KW	0.6 KW

Functional Overview

Switch Configuration for Optimum Performance

The flexibility of the 8270 allows the system to be configured to meet the network topology requirements of an individual establishment. Any mix of token-ring 4-port copper and 2-port fiber UFCs can be used in the 8270. The port speeds might be a mix of both 4 and 16 Mbps or all ports might operate at the same speed. Some ports can operate as dedicated full-duplex links while others operate as shared links.

The following configuration guidelines should be observed:

- The ATM UFC will allow traffic flow to or from the Token-Ring ports. ATM-to-ATM traffic flow will be blocked by the 8270.
- An ATM UFC, a 2-port Fiber UFC, and MSS Client, or MSS Domain Client UFC should be installed in slot 1 of the 8270-800. Only the first two ports of a 4-port UFC will be operational in slot 1.

The internal data capacity of the 8270 is 480 Mbps. Port buffering for both the transmit and receive paths permit data bursts exceeding this capacity to be handled without frame loss. Some frame loss is normal for all switch configurations. Excessive frame loss that affects end-user performance is usually an indication of a traffic imbalance that can usually be remedied by repositioning of client and server stations. Frame traffic should be distributed across several ports on a switch for optimum switch performance. Token-Pipes should be on switch-to-switch links to match the projected traffic capacity or if excessive packet loss is observed.

Additional performance information for the 8270 can be made available by IBM through other documents or publications. Independent test organizations have measured and published performance data regarding the 8270 products.

Interconnected Switches

Connect any 8270 port to another switch in either HDX or FDX mode, or as part of a TokenPipe connection.

Shared Media

Shared media consists of two or more Token-Ring LAN stations that share the 4- or 16-Mbps LAN segment. Connect these ports to Token-Ring devices such as multistation access units (MSAUs), Token-Ring concentrators, or Token-Ring hubs, using the 802.5 Token-Passing Protocol.

Dedicated Media

Create *dedicated media* by directly attaching a single Token-Ring LAN station adapter to a switch port without an intervening Token-Ring concentrator or hub. You can then operate the LAN station adapter as a dedicated Token-Ring device in HDX (4 or 16 Mbps) or FDX (8 or 32 Mbps) mode.

UFCs

UFCs provide switch ports, support other Token-Ring media, or provide high-bandwidth uplinks. Refer to each individual UFC *Planning and Installation Guide* for UFC interconnectivity requirements.

Chapter 2. Network Planning and Installation Preparations

Preparations

The following suggestions will help you prepare for the installation of your 8270:

1. Make a sketch of the network to which you will be adding one or more 8270s, especially if your institution is a large one. Be sure to include major elements of the network such as hubs and concentrators as well as servers, bridges, and routers.
2. Get connectivity and physical planning information about the network segments to which you will be attaching your 8270.
3. If you will be using permanently installed telecommunications wiring, get information about the cabling installation that will allow you to determine the termination points of every cable, the cable type, connector type (if any), and the distance between termination points.
4. Get building floor plans and telecommunications closet layouts.
5. Read the material in this chapter and Chapter 3, "Configuration."
6. Fill out the planning charts and worksheets discussed in "Using Planning Charts and Worksheets" on page 2-11. Retain these sheets for use if it becomes necessary to reconfigure the 8270.

Rules to Remember

This section can help you understand the physical configuration restrictions for the 8270. In brief, you must remember the following rules when planning to install the 8270:

- 4540-byte maximum frame length.
- For shared-media LAN segments, acceptable distances are defined by the hub or concentrator attached to the 8270 port.
- Straight-through cables for all Token-Ring ports.
- If you create parallel transparent paths directly between 8270s, be sure that you have enabled 802.1d Spanning Tree. (See "Transparent Bridge Spanning Tree" on page 3-21.) The default setting for Spanning Tree is disabled.
- Use star-wired topology for interconnected 8270s.
- Read the READ.ME file at <http://www.networking.ibm.com/support> for any new restrictions or cautions.
- If a 4-port UFC is installed in UFC slot 1 of the 8270-800, ports 3 and 4 will not operate.

The following paragraphs provide greater detail about the physical restrictions.

Frame Length Limit

The 8270 supports a maximum frame length of 4540 bytes (from the Frame Control [FC] to Frame Check Sequence [FCS] characters). Be sure to configure all network software, interconnecting products, workstations, and user applications so that they do not send frames larger than 4540 bytes.

In Cut-Through mode, the 8270 truncates frames larger than 4540 bytes and adds an abort sequence at the end. Characteristically, if frames are sent larger than the 4540-byte limit, a network manager will detect abort sequences from the 8270.

In Store-and-Forward mode, a switch port rejects larger frames and a soft error will be generated on that port's LAN segment.

Cables and Distances between Devices

The 8270 supports attachment to 100-ohm and 120-ohm twisted-pair (STP or UTP), and 150-ohm STP, as defined in the EIA/TIA 568A and ISO/IEC 11801:1995.

The following sections define the distances allowed for different types of connections.

Dedicated-Media LAN Segment Rules

Dedicated-media LAN segments are those segments that directly interconnect two 8270 ports, or connect an 8270 port directly to a Token-Ring adapter. A direct connection permits a longer segment length than is normally recommended by the cabling standards. Make sure that you use category 3 or better components when patching cables. For specific cabling information and maximum length limitations, refer to the *8270 Installation and Service Guide*— available on the 8270 CD-ROM.

Shared-Media LAN Segment Rules

Shared-media segments are segments that connect an 8270 port to a Token-Ring access unit or concentrator. For a shared-media LAN segment, the 8270 port emulates a Token-Ring station; therefore, the applicable wiring rules are those defined by the hub or concentrator to which the port is attached.

Cable Wiring

Always use straight-through cables for Token-Ring ports.

Some devices might require special cabling, and their rules must be met. For more information on cabling, refer to the *8270 Installation and Service Guide*— available on the 8270 CD-ROM.

8270 Security

When planning for installation of the 8270, the following security measures should be considered:

- The 8270 has two levels of password protection. The Read Only password allows access to switch statistics only. The Read/Write password allows the user to change switch configuration parameters. See "Password" on page 3-51.
- In addition to password protection, the 8270 can filter traffic based on MAC address or only allow specified MAC addresses to traverse the switch. See

“Configuring Filters” on page 3-43 and “Configuring Port Security Mode” on page 3-45.

- The 8270 also prevents unauthorized access to the switch by remote management applications via SNMP read/write protection based on community name. See “Creating Communities” on page 3-19.
- The 8270 allows the user to erase the password through the System Request Menu, without knowing the configured password, by clearing nonvolatile RAM. Clearing nonvolatile RAM resets all user configured switch configuration parameters back to the factory defaults, including the passwords, filters, port security parameters and SNMP information. Because of this, physical security of the 8270 should be considered to prevent unauthorized access to the System Request button.

Sample Applications

The 8270 allows you to make incremental changes in your network to address both immediate and long-range performance challenges. For example, a Token-Ring LAN of 80 stations including 4 servers might experience performance problems as a result of increased traffic. As it is currently structured, the LAN looks like the one in Figure 2-1.

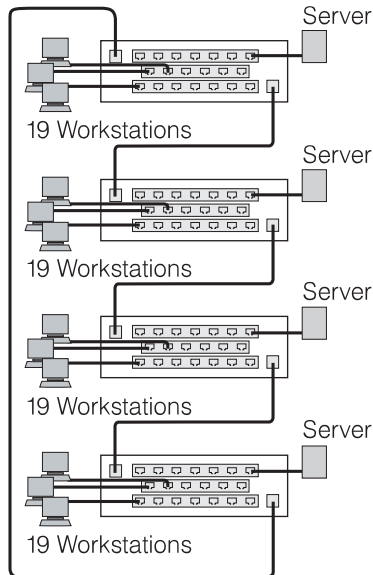

Figure 2-1. Typical Token-Ring LAN Segmentation

All of the stations are attached to access units located in a single wiring closet. You can install an 8270 in the same wiring closet and divide the LAN into 4 segments of 20 stations each (as depicted in Figure 2-2). One access-unit port from each segment will be connected to a port on the 8270 via a patch cable. Finally, the four servers are removed from the access units to which they have been attached and their cables moved to four ports on the 8270.

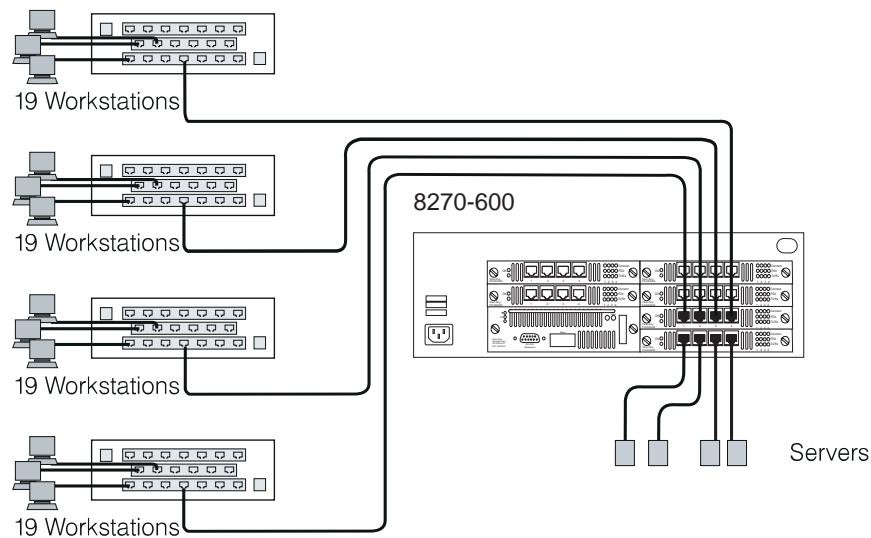

Figure 2-2. A Simple Application of the 8270-600

Each group of 19 users attached to an access unit now shares a dedicated, 16-Mbps path to the server. Each server has a dedicated, 16-Mbps path upon which to service requests. The overall capacity of this solution is 64 Mbps; network capacity has increased four-fold.

Some large, multisegment, hierarchical Token-Ring networks experience congestion at the campus backbone level. Although this congestion can often be relieved by converting the backbone to a higher speed, shared-media protocol or by installing additional bridges or dual backbones to eliminate bottlenecks, the 8270 offers dedicated media that might be longer lived or more economical if you eventually need higher demand applications or an ATM WAN. Figure 2-4 on page 2-6 and Figure 2-5 on page 2-7 offer several alternatives for using 8270 switches in the network shown in Figure 2-3. This network is a three-level, hierarchical, campus network.

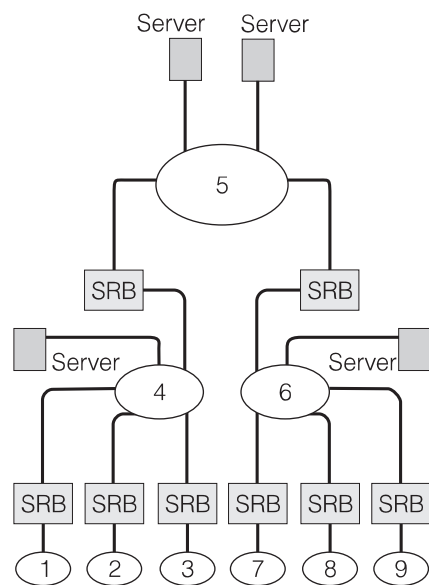

Figure 2-3. Typical Network without the 8270

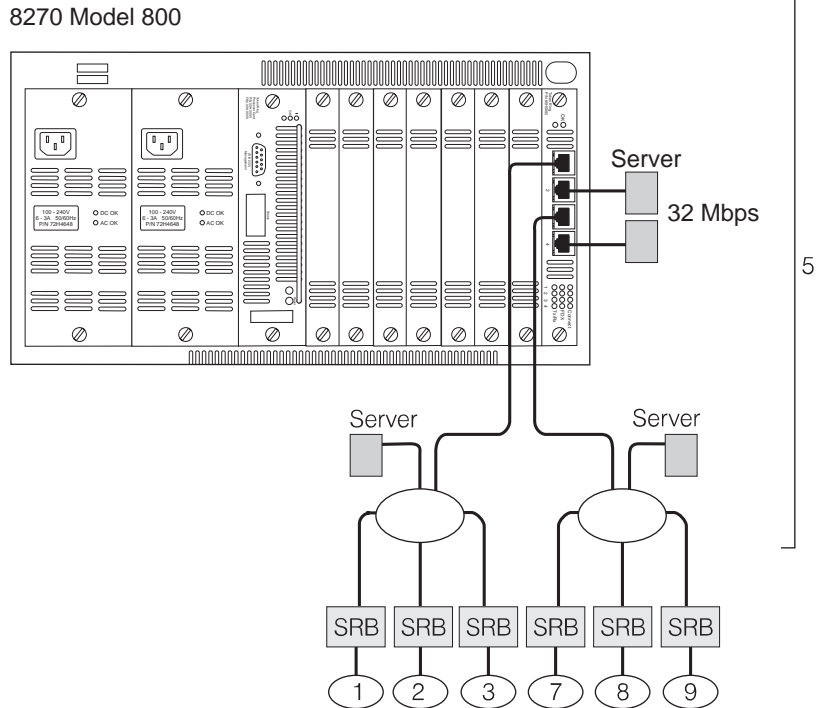

Figure 2-4. Relieving the Overstressed Backbone

In Figure 2-4, the congested campus backbone and the source-routing bridges (SRBs) attached to it have been replaced by an 8270. LAN segments 4, 5, and 6 in Figure 2-4 have become a single segment (identified as number 5 in the sketch).

The Next Step

Typically, the first point of congestion in this newly configured network would be the servers. Because the usual mode of operation for a Token-Ring adapter is HDX, the servers can either send or receive information with one other segment attached to the switch. So, if the servers are equipped with FDX adapters, such as the IBM Auto LANStreamer MC 32 Adapters attached as single-station segments as shown in Figure 2-4, they can send and receive data simultaneously. The capacity of each server is now 32 Mbps per port (64 Mbps for the Dual LANStreamer Adapter).

However, network congestion is not always at the backbone level. Figure 2-5 on page 2-7 shows a network where rings 4 and 6 and all of the bridges around them have been replaced with 8270s. All of the stations in the former rings 1 through 9 are now seen as part of a single logical segment. Bottlenecks between users and departmental servers have been markedly decreased.

Finally, when the traffic on the backbone increases, the optional ATM uplink feature of the 8270 allows you to connect to a scalable ATM network through the 8270, as shown in Figure 2-6 on page 2-7.

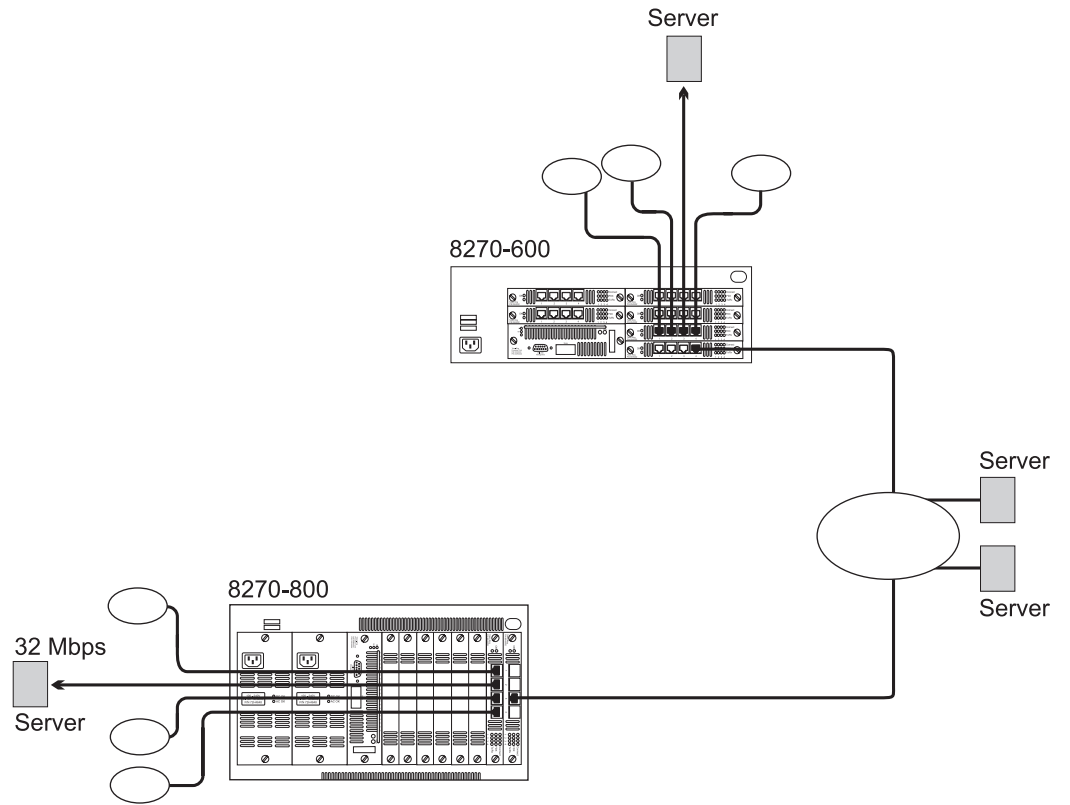

Figure 2-5. Using Multiple 8270s

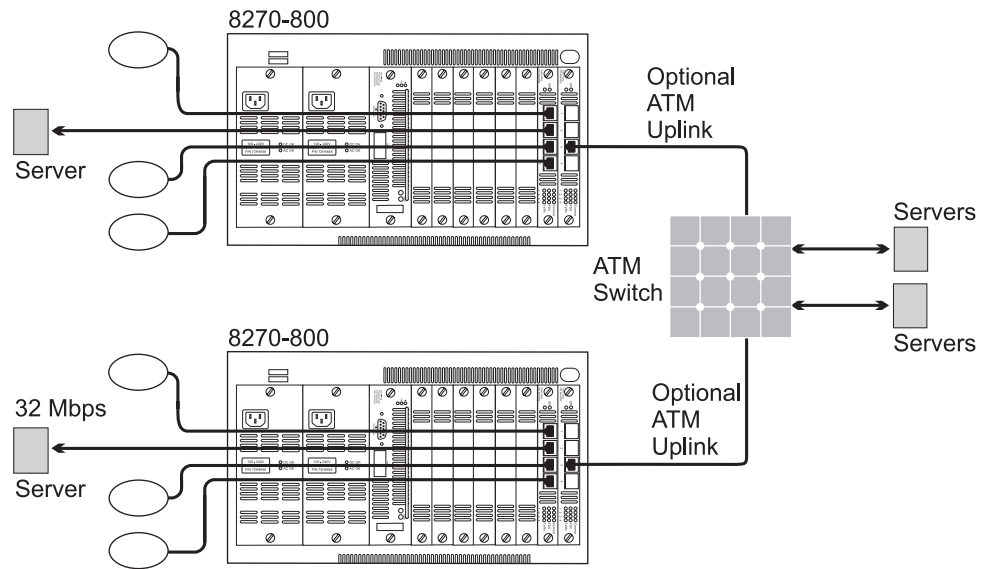

Figure 2-6. ATM Uplink Feature in a Network

Using source-route Switching and Bridging

Figure 2-7 shows an example of using a single 8270 configured with virtual domains and source-route bridging to eliminate multiple, external source-route bridges. In the example, the 8270 is configured with four virtual switch domains, three of which are enabled for source-route bridging. Source-route switching is used within all of the domains, and source-route bridging is used between those domains enabled for source-route bridging. Both explorer and specifically routed frames are source-route bridged to other domains. In the example, the internal source-route bridge eliminates the need for up to three external source-route bridges.

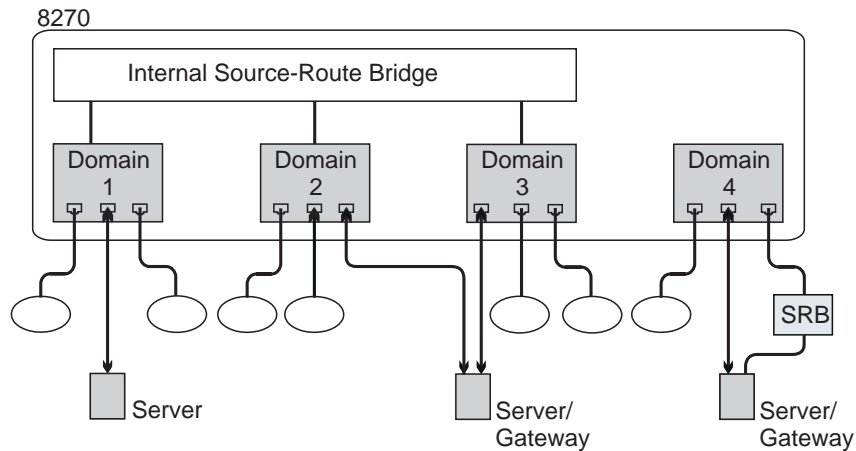

Figure 2-7. Using the Internal Source-Route Bridge Function

Important Management Considerations

From a performance perspective, a cascaded network topology is recommended when planning your 8270 installation.

A star-wired topology (see Figure 2-8 on page 2-9) helps achieve maximum bandwidth and helps determine problems in a network because no single cable carries all of the traffic on the network. However, serial connections could reduce network capacity since each connecting cable and 8270 could potentially divide the network should a failure occur.

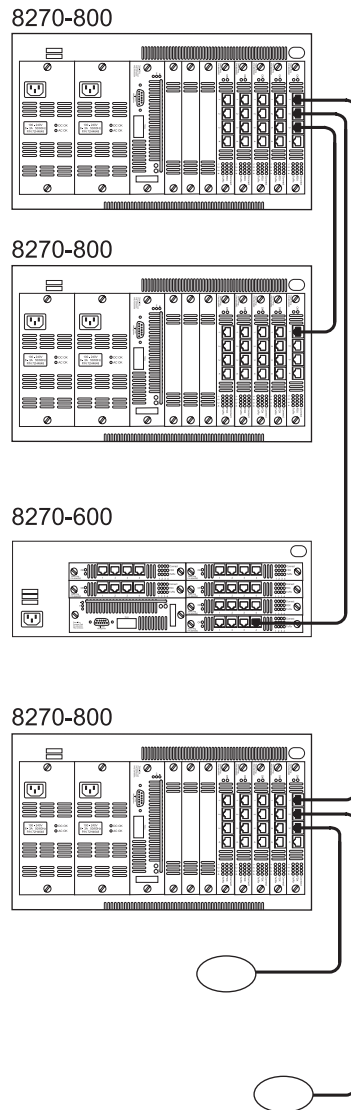

Figure 2-8. Star-Wired Topology of Interconnected 8270s

If you create parallel transparent paths directly between 8270s, be sure that you have enabled IEEE 802.1 (the 8270 default setting for Spanning Tree is No or disabled). Parallel paths create endless loops that cause unsatisfactory network operation unless you configure the 8270 for Spanning Tree capability. The Spanning Tree algorithm disconnects loops in networks using the IEEE 802.1d standard, and blocks a port of one of the 8270s in the parallel paths. If the port in the primary path fails, the port that has been blocked changes automatically to the forwarding state, keeping the network operational.

8270 Embedded RMON Feature

Remote monitoring (RMON) support for Token-Ring is defined by RFC1757 and RFC1513. RFC1757 (the RMON MIB) contains the base RMON groups while RFC1513 (the Token-Ring RMON MIB) contains the Token-Ring specific tables and extensions to RFC1757. The Embedded RMON Feature of the IBM 8270 LAN Switch will provide support for the statistics, history control, history, alarm and event groups. The following table lists the groups contained in RFC1757 and RFC1513,

and indicates which groups are supported by the Embedded RMON Feature of the 8270.

Table 2-1. Token-Ring RMON Groups

Group	Supported	Standard
token-ring statistics	yes	RFC1513
history control	yes	RFC1757
token-ring history	yes	RFC1513
alarm	yes	RFC1757
host	no	RFC1757
hostTopN	no	RFC1757
matrix	no	RFC1757
filter	no	RFC1757
packet capture	no	RFC1757
event	yes	RFC1757
token-ring station	no	RFC1513
token-ring station order	no	RFC1513
token-ring station config	no	RFC1513
token-ring source routing	no	RFC1513

An IBM Technical Report (TR 29.2256) is available on this CD-ROM with more information about the Embedded RMON feature of the 8270.

Using Planning Charts and Worksheets

As part of the planning process, you should complete the charts and worksheets found in Appendix A, "Planning Charts and Worksheets."

8270 Cabling Chart

The 8270 installer uses this chart to place the 8270 in its assigned location and to connect the appropriate cables.

8270 Configuration Panel worksheets

Prepare a set of worksheets for each 8270 you plan to install. Worksheet parameters match those on the panels that appear on the console attached to the EIA 232 port.

Locator Charts

These charts relate adapter addresses to physical locations and device identification numbers. These charts are useful for problem determination; you should keep them current, especially in large institutions.

In addition to the charts and worksheets discussed above, a Service Information Card is provided. This card is a ready reference for service personnel and contains information about LEDs, the Status display, and cabling. You should fill in the appropriate cabling information in the spaces provided.

All of the documentation discussed above should be retained and updated anytime changes are made. This information is required if it ever becomes necessary to restore the system configuration.

When installing UFCs, refer to the documentation shipped with the UFC for planning, management, and configuration.

Chapter 3. Configuration

The 8270 is shipped with default configuration settings that allow it to operate satisfactorily in simple networks. In such cases, it is not necessary for you to change the configuration. However, a console interface via the EIA 232 port is provided so that you can customize the 8270, monitor its activity, and troubleshoot problems. This chapter tells you how to set up a console session and configure the 8270.

You can set up a console session locally by directly connecting a PC or other DTE to the EIA 232 port on the 8270. You also can set up a console session remotely by connecting a modem to the EIA 232 port and then dialing in from your remote station. To connect a terminal directly to the 8270, continue with "Connecting a Local Terminal." To use a modem, go to "Connecting a Modem to Allow Remote Terminal Access" on page 3-2.

Connecting a Local Terminal

To connect a local terminal to the 8270, perform the following steps:

- Step 1.** Begin running your terminal emulation software on the PC or other DTE to which you will be connecting the 8270.
- Step 2.** Set the terminal as follows. See "Serial Link Configuration" on page 3-54.

Note: Some emulators do not have all of the options listed below.

Baud rate	1200, 2400, 4800, 9600, 19200, 38400, 57600 (9600 is the default)
Parity	None
Data bits	8
Stop bits	1
Handshaking	None
Terminal emulation	VT100
Duplex	Full
Software flow control (XON/XOFF)	Off
Hardware flow control (RTS/CTS)	Off
Line wrap	Off
Screen scroll	On
CR translation	CR
Backspace (BS) translation	Destructive
Break length (milliseconds)	350
Enquiry (ENQ)	Off
EGA/VGA true underline	Off
Terminal width	890
ANSI 7- or 8-bit commands	7

- Step 3.** If you are using Microsoft Windows terminal emulation, set the Function, Arrow, and Ctrl Keys to act as terminal keys instead of Windows keys.
- Step 4.** Connect the EIA 232 port on the 8270 to your PC or DTE device using a null-modem cable or straight-through cable and null-modem adapter. The 8270 has a 9-pin, male connector. For pinout and cable information, see Appendix A, "Planning Charts and Worksheets."
- Step 5.** Press the **Reset** button. The Reset LED comes on. The 8270 will then perform a series of self-test diagnostics, which might last between 4 and 7 minutes.
- Step 6.** When the Reset LED goes off, diagnostics are complete.

Connecting a Modem to Allow Remote Terminal Access

You can monitor the 8270 remotely by using any Hayes-compatible modem. To connect a modem to the 8270, perform the following steps:

- Step 1.** Set up your modem according to its instructions. Place it near the 8270.
- Step 2.** Connect the cable from the EIA 232 port on the modem to the EIA 232 port on the 8270. (For cable information, see Appendix A, "Planning Charts and Worksheets.")
- Step 3.** Set the modem as indicated below. If you uses settings other than the ones listed, you can cause the 8270 to reset when the modem is powered on.

Note: Some modems do not have all of these options. Also, some modems use slightly different names for the options.

Echo	Off
Result codes	Off
Auto-answer	On first ring
Wait for connection	45 seconds
Pause between calls	6 seconds
Auto baud detect	On
Drop DTR between calls	Yes
Send CR between calls	Yes
Send init if CD high	Yes
Maximum dial attempts	999

- Step 4.** Prepare your remote terminal by following steps 1 and 2 under "Connecting a Local Terminal" on page 3-1.
- Step 5.** Dial in to the 8270 modem from your remote site.

Default Configuration Parameters

Parameter	Default Setting
Port Domain Assignment	All ports are assigned to domain 0 , which is named Default . For further information, see "Configuring Domains" on page 3-13.

IP Address	0.0.0.0 For further information, see “Setting Up IP Addresses” on page 3-15.
Default Gateway	0.0.0.0 For further information, see “Setting Up IP Addresses” on page 3-15.
Subnet Mask	0.0.0.0 For further information, see “Setting Up IP Addresses” on page 3-15.
IP State	BootP When Needed For further information, see “IP State for Domains” on page 3-15.
Send Authentication Traps	Yes For further information, see “Configuring SNMP” on page 3-18.
Participate in Spanning Tree	No For further information, see “Transparent Bridge Spanning Tree” on page 3-21.
Switch Priority	32768 (if participating in Transparent Spanning Tree) For further information, see “Transparent Bridge Spanning Tree” on page 3-21.
Switch Hello Time	2 seconds (if participating in Transparent Spanning Tree) For further information, see “Transparent Bridge Spanning Tree” on page 3-21.
Switch Maximum Message Age	20 seconds (if participating in Transparent Spanning Tree) For further information, see “Transparent Bridge Spanning Tree” on page 3-21.
Switch Forward Delay	15 seconds (if participating in Transparent Spanning Tree) For further information, see “Transparent Bridge Spanning Tree” on page 3-21.
Port Cost	62 (if participating in Transparent Spanning Tree) For further information, see “Port Parameters” on page 3-23.
Port Priority	128 (if participating in Transparent Spanning Tree) For further information, see “Port Parameters” on page 3-23.

Port Switching Mode	Adaptive For further information, see “Switching Mode” on page 3-26.
Port State	Enabled For further information, see “State” on page 3-26.
Port Configuration Type	Auto For further information, see “Config Type” on page 3-26.
Configuration Loss Threshold	8 For further information, see “Config Loss” on page 3-27.
PAT Demand Aging Level	90% For further information, see “Port Address Table Aging” on page 3-29.
MAT Demand Aging Level	90% For further information, see “Master Address Table Aging” on page 3-30.
LAN Segment Number	unknown (switch must learn the LAN segment number or have one assigned) For further information, see “Assigning or Changing LAN Segment Numbers” on page 3-33.
Bridge Number	1 For further information, see “Internal Source-Route Bridge Configuration” on page 3-34.
Max ARE Frame Xmit Hop Cnt	7 For further information, see “Changing LAN Segment Bridging Parameters” on page 3-36.
Max ARE Frame Rcv Hop Cnt	7 For further information, see “Changing LAN Segment Bridging Parameters” on page 3-36.
Max STE Frame Xmit Hop Cnt	7 For further information, see “Changing LAN Segment Bridging Parameters” on page 3-36.
Max STE Frame Rcv Hop Cnt	7 For further information, see “Changing LAN Segment Bridging Parameters” on page 3-36.
Maximum Frame Size	4472 For further information, see “Changing LAN Segment Bridging Parameters” on page 3-36.

SRB Priority	32768 For further information, see “Source-Route Bridge Spanning Tree Configuration” on page 3-38.
SRB Hello Time	2 sec For further information, see “Source-Route Bridge Spanning Tree Configuration” on page 3-38.
SRB Maximum Message Age	6 sec For further information, see “Source-Route Bridge Spanning Tree Configuration” on page 3-38.
SRB Forwarding Delay	4 sec For further information, see “Source-Route Bridge Spanning Tree Configuration” on page 3-38.
Segment Path Cost	62 For further information, see “Source-Route Bridge Path Cost” on page 3-40.
Single-Route Bcast Frame State	Forward For further information, see “Source-Route Bridge (SRB) Manual Spanning Tree Parameters” on page 3-41.
Port Security Mode	Normal For further information, see “Configuring Port Security Mode” on page 3-45.
Error Rate High Threshold	10% For further information, see “Switching Mode Threshold (Token-Ring Ports only)” on page 3-49.
Error Rate Low Threshold	1% For further information, see “Switching Mode Threshold (Token-Ring Ports only)” on page 3-49.
Error Rate Trend	1% For further information, see “Switching Mode Threshold (Token-Ring Ports only)” on page 3-49.
Error Rate Sample Period	10 sec For further information, see “Switching Mode Threshold (Token-Ring Ports only)” on page 3-49.
Set Password	(none) For further information, see “Password” on page 3-51.

Console Timeout	0 min For further information, see “Console Configuration” on page 3-53.
Hardware Flow Control	Disabled For further information, see “Serial Link Configuration” on page 3-54.
Software Flow Control	Disabled For further information, see “Serial Link Configuration” on page 3-54.
Autobaud Upon Break	Enabled For further information, see “Serial Link Configuration” on page 3-54.
Console Baud Rate	9600 For further information, see “Serial Link Configuration” on page 3-54.
Number of Telnet Sessions Allowed	5 For further information, see “Telnet Configuration” on page 3-55.
Disallow New Telnet Sessions	No For further information, see “Telnet Configuration” on page 3-55.

Use the Configuration process described in the rest of this chapter to change any of the preceding default parameters.

Preparing to Configure the 8270

Preparations for configuring the 8270 involve configuring UFCs and setting up a console session.

Configuring a UFC

Review the configuration instructions shipped with any UFCs that are installed in the 8270 now, and then return here.

If your UFC configuration instructions require you to load new microcode, do so before continuing. If you configure the 8270 and then load new microcode, the configuration data might be lost.

Navigating the Console Panels

Follow these guidelines during a console session:

- To change a value, perform an action, or display a new panel, select an item using the cursor keys, and press **Enter**. Selected items are highlighted. You are then prompted to enter data, select from a list of valid choices, or a new panel is displayed. The prompts appear just below the line containing action items (Return, Add, and so on). The third line from the bottom (also highlighted), acts as a *Help* line, providing brief descriptions and explanations of selected items.
- When a menu or panel consists of more than one part, the **More** action item is displayed. Selecting More causes the next part of the current panel to be displayed.
- Selecting the Return action item, returns you to the previously displayed panel.
- To save in NVRAM any changes made on the configuration panels, select **Return** on the panel whose settings you want to save.

Note: Selecting Return is the only way to save any changes made on the configuration panels.

- To return to the Main Menu, press **Ctrl+N**.
Attention: Changes made to the current panel are **not** saved.
- To return to the copyright panel, press **Ctrl+B**.
- To refresh the console screen at any time, press **Ctrl+L**.

Beginning the Console Session

After you have connected and configured a local or remote terminal (see “Connecting a Local Terminal” on page 3-1), proceed as follows:

- Step 1.** Press **Enter** repeatedly until a panel similar to the one in Figure 3-1 appears on your display. If no panel appears, make sure that you have made all of the correct settings and are using the correct type of cables.

```
IBM 8270 Nways Token-Ring LAN Switch Model 800

(c) Copyright International Business Machines Corporation
    and others, 1995 -1998 All rights reserved.

Switch Base MAC Address:      0004AC A301E0

System Contact:

    A later level of 8270 microcode may be available
    electronically. Consult the current Release Notes for
    Detailed Instructions.

    Type Password, then press <ENTER>:

    -- No password has been set, press <ENTER> to continue. --
```

Figure 3-1. Copyright Panel

- Step 2.** Type the password, if one has been configured. The default password is pressing Enter.

Note: If you have forgotten your password, press the **System Request** button to access the System Request menu, and then select **Clear NVRAM**. This clears the password and sets all configuration parameters to their default values, *clearing any values you have entered*.

- Step 3.** Then, press **Enter** to advance to the Main Menu as shown in Figure 3-2 on page 3-9.

Note: To terminate a Telnet session, press **Ctrl+B**.

Main Menu

In the Main Menu, the first selection item, Configuration, is covered in the remainder of this chapter. The other three selection items are covered in subsequent chapters.

```

Main Menu
Configuration...
Status/Statistics...
Reset/Diagnostics...
Non-Token-Ring Ports Menu...
Download...

Exit

Exit local console menus or terminate remote console session
Use cursor keys to choose item. Press <ENTER> to confirm choice.
Press <CTRL><N> to exit console.
```

Figure 3-2. Main Menu

Selecting any of the listed items on the Main Menu takes you to the first panel of the indicated function.

Configuration Menu

From the Main Menu, select **Configuration...** to display the Configuration Menu as shown in Figure 3-3.

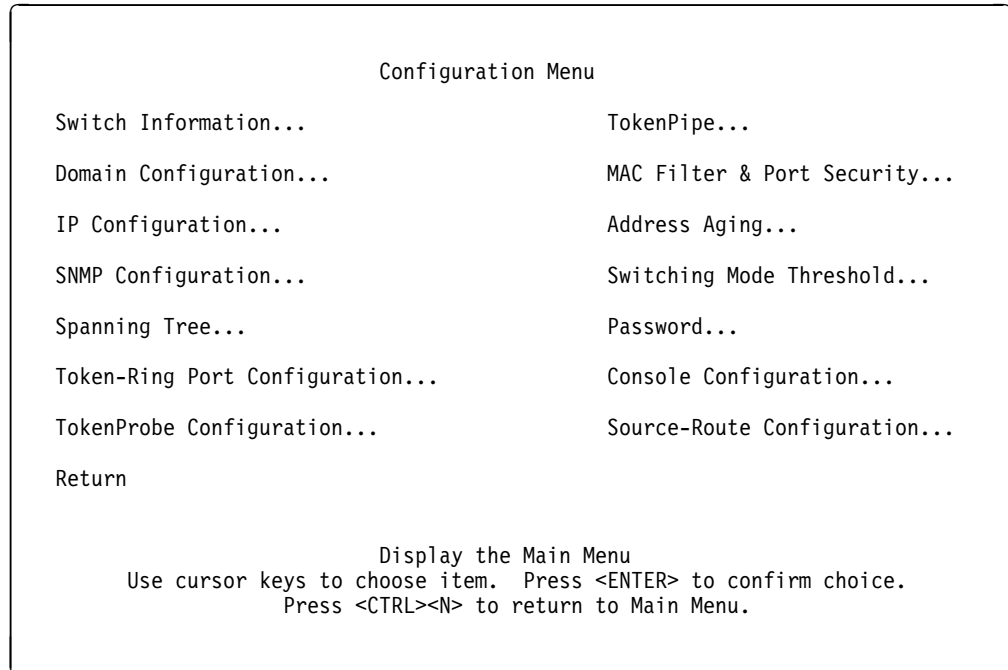

Figure 3-3. Configuration Menu

Selecting any of the listed items on the Configuration Menu takes you to the first panel of the indicated function.

Viewing Switch Information

From the Configuration Menu, select **Switch Information...** Use the Switch Information panel to view or change the parameters, system name, system location, or system contact. Figure 3-4 shows sample data.

```
Switch Information

System Description      IBM 8270 Nways Token-Ring LAN Switch Model 800
System ID              1.3.6.1.4.1.2.6.66.1.1.800
Switch Base MAC Address 10005A 2B1220
Address Format          Noncanonical
Interface Description   8270 Nways HW Rev 0; SW 2.0
                      (Nov 1 1997 10:00:00) Port uCode KS18C7
System Name            Payroll 1
System Location         Building 200

System Contact         Jane Doe

DRAM Installed         4 MB
Time of Day...         Mon. January 16, 1998 12:17:34

Return

Display the Configuration Menu
Use cursor keys to choose item. Press <ENTER> to confirm choice.
Press <CTRL><N> to return to Main Menu.
```

Figure 3-4. Switch Information Panel

The following list describes the information and parameters shown on the Switch Information panel.

System Description

Shows the full name and version identification of the system's hardware type.

System ID

Shows the unique identification code for this 8270 that was assigned at the factory. It serves a purpose similar to that of a serial number.

Switch Base MAC Address

Displays the MAC address of the 8270.

Address Format

Allows you to choose to display MAC addresses in canonical or noncanonical format. Canonical format is typically used in Ethernet and is also known as *least significant bit (LSB) first*. Noncanonical is typically used in Token-Ring and is also known as *most significant bit (MSB) first*.

Interface Description

Shows the hardware and software version of the 8270. The port microcode level applies to code related to physical port function.

System Name

Displays and allows you to enter the locally assigned name.

System Location

Displays and allows you to enter the locally assigned location.

System Contact

Displays and allows you to enter the locally assigned contact name.

DRAM Installed

Displays the number of megabytes of memory installed.

Time of Day

Allows the user to set the internal clock of the 8270.

Configuring Domains

From the Configuration Menu, select **Domain Configuration...** to display the Domain Configuration panel as shown in Figure 3-5. On the Domain Configuration panel, you can partition a single 8270 into a maximum of 16 domains. Except for those domains enabled for source-route bridging, each domain acts like a separate switch. A domain can be configured with its own IP address and managed with SNMP. Any domain can participate independently in the Spanning Tree protocol. Once domains have been established, packets are forwarded between ports belonging to the same domain only, if the domain is not enabled for source-route bridging.

Note: When port numbers are displayed in the following panels, the ports are identified by the UFC slot number and the port number on that slot (for example, port 3 on slot 2 appears as 2-3).

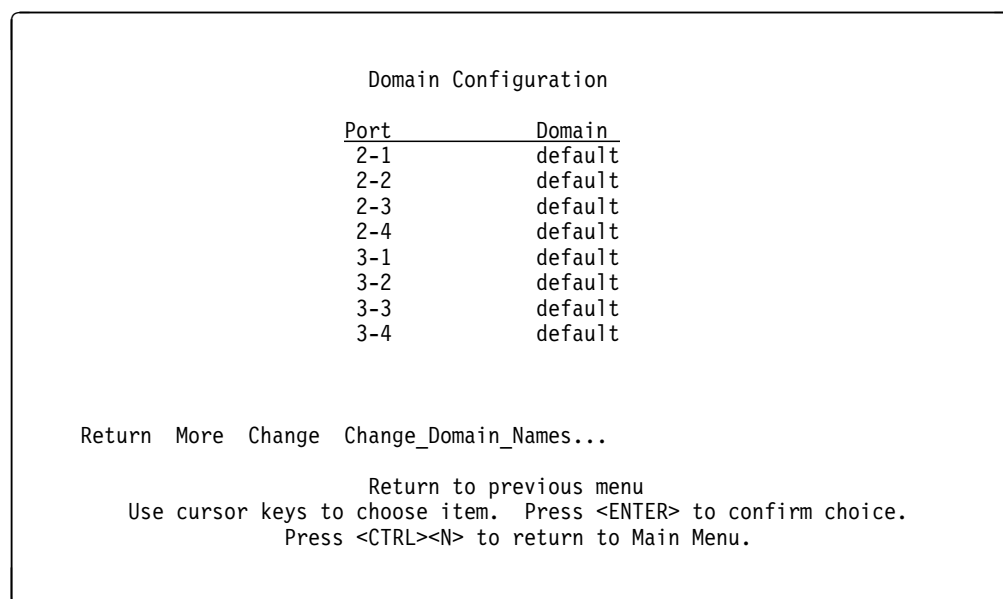

```
Domain Configuration

Port      Domain
-----
2-1      default
2-2      default
2-3      default
2-4      default
3-1      default
3-2      default
3-3      default
3-4      default

Return More Change Change_Domain_Names...

Return to previous menu
Use cursor keys to choose item. Press <ENTER> to confirm choice.
Press <CTRL><N> to return to Main Menu.
```

Figure 3-5. Domain Configuration Panel

To see additional ports, select **More**.

The Port column displays the number of the port that you want to assign to a domain (0–15). All ports are initially assigned to the default (domain 0). The Change option in the Configuration Menu brings up the panel shown in Figure 3-6 on page 3-14. This panel allows you to change the name of each domain.

For each domain that you establish, you can set up IP parameters (see “Setting Up IP Addresses” on page 3-15), SNMP trap tables (see “SNMP Network Management” on page 3-17), and Spanning Tree parameters (see “Transparent Bridge Spanning Tree” on page 3-21).

Naming Domains

From the Domain Configuration panel, select **Change_Domain_Names...** to display the Domain Names panel. This panel allows you to change the names of each domain from the default name to a name of your choosing.

Domain Names	
<u>Index</u>	<u>Name</u>
0	default
1	Domain01
2	Domain02
3	Domain03
4	Domain04
5	Domain05
6	Domain06
7	Domain07
8	Domain08
9	Domain09
10	Domain10
11	Domain11
12	Domain12

Return More Change

Return to previous menu
Use cursor keys to choose item. Press <ENTER> to confirm choice.
Press <CTRL><N> to return to Main Menu.

Figure 3-6. Domain Names Panel

Select **Change** to change the name of a domain from the default value to a name of your choosing. This panel shows the domains that can be created and their default names.

Setting Up IP Addresses

From the Configuration Menu (see Figure 3-3 on page 3-10), select **IP Configuration...** to set the IP address, gateway address, subnet mask, and IP state, and to send PINGs. Figure 3-7 shows the IP Configuration for domain “default”.

```
IP Configuration for Domain: default

Change_Displayed_Domain...

IP Address           0.0.0.0
Default Gateway     0.0.0.0
Subnet Mask         0.0.0.0
IP State             BootP When Needed
Send PING

Return

Display the Configuration Menu
Use cursor keys to choose item. Press <ENTER> to confirm choice.
Press <CTRL><N> to return to Main Menu.
```

Figure 3-7. IP Configuration Panel

IP addresses are always entered as a set of 4 decimal numbers from 0 through 255. The numbers must be separated by periods. The default is 0.0.0.0. If the default is used, no SNMP management is available. The default gateway and default subnet mask are both 0.0.0.0. The settings take effect when you leave this panel.

IP State for Domains

The choices for IP state are IP Disabled, BootP When Needed, and BootP Always. The default is BootP When Needed. The following list explains the meaning of each of these parameters:

IP Disabled

The domain will not process any IP or Address Resolution Protocol (ARP) frames it receives. It will not respond to SNMP, PING, Telnet, or ARP frames that are received.

BootP When Needed

IP is enabled for the domain and will function immediately, if a non-0 IP address has been stored in NVRAM. If the IP address is 0 (0.0.0.0), BootP requests will be broadcast by the 8270 in an effort to learn its IP address. Until the 8270 receives a reply, this is the only IP function that will work.

BootP Always

IP is enabled for the domain but will not function until a BootP reply has been received. If a non-0 IP address for the domain is stored in NVRAM, it is set to 0 when the 8270 is booted.

Note: When you select either of the BootP options in the preceding list, the 8270 repeats BootP requests at regular intervals, beginning at one second and eventually decreasing to every five minutes until it has received a valid reply. The BootP requests will also cease if a valid IP address is configured or the IP state is set to IP Disabled.

Once the 8270 stops sending BootP requests on a domain, it does not resume sending requests or recognize BootP responses on that domain unless the 8270 is reset. The parameters in a BootP response that are recognized and recorded in NVRAM are:

- IP Address
- Default Gateway
- Subnet Mask
- TFTP Bootfile Name
- TFTP Server Address

Send PING

The system prompts you to enter an IP address. The 8270 sends a PING to that address when you return to the Configuration panel. To send a PING to the BootP server, enter the IP address for the server you want to PING.

SNMP Network Management

See <http://www.networking.ibm.com/support> for the diskette image containing the private MIBs necessary for managing an 8270 with an SNMP-based network manager, such as Nways Campus Manager LAN for AIX, Nways Manager for Windows or Nways Campus Manager LAN for HP/UX**.

The SNMP agent in an 8270 maintains management information bases (MIBs), consisting of objects that contain information about the 8270's identity, status, and resources. The SNMP network manager can request that the 8270 report information in the MIBs or set values in the MIBs.

Table 3-1. MIBs Implemented in the 8270 SNMP Agent

MIB	RFC
8270/8272 Private MIB	None
MIB-2	1213
Interface MIB	1573
Etherlike MIB	1643
Token Ring MIB	1231
Bridge MIB	1493
Source Routing MIB	1525
RMON MIB	1757
RMON Token Ring MIB	1513
ATM MIB	1695
LAN Emulation Client MIB	ATM Forum
Discovery MIB	None
Note: Printed copies of RFCs are available for a fee from: SRI International, Room EJ291 333 Ravenswood Avenue Menlo Park, CA 94025 (415) 859-3695 (415) 859-6387 FAX (415) 859-6028 Request a softcopy of an RFC through an Internet mail gateway service (ATTMAIL, MCIMAIL, CompuServe**, BITNET, and so on) as follows: Address: SERVICE@NIC.DDN.MIL Subject: RFC <i>number</i> <i>number</i> is the number of the RFC you are requesting.	

All except the first MIB are standard MIBs. The 8270 SNMP agent implements some elements of each of these eight MIBs, which are listed in Table 3-1 along with the Internet Requests for Comments (RFCs) that define them. These standard MIBs are included with most SNMP management applications.

Step 1. If your network is SNMP-managed, give this diskette to the network management operator so that it can be compiled into the SNMP-based network manager.

Step 2. If you are not currently using an SNMP manager, store the diskette for future use.

Note: If you are using SNMP management, once you have entered the initial IP address and SNMP configuration parameters from the console, you can use either the console or an SNMP managing entity with the MIBs loaded to view or change all parameters or management information except transparent Spanning Tree parameters.

Configuring SNMP

Before configuring SNMP, be sure that you have set IP addresses for the switch and each configured domain.

From the Configuration Menu, select **SNMP Configuration...** to set specific attributes related to SNMP.

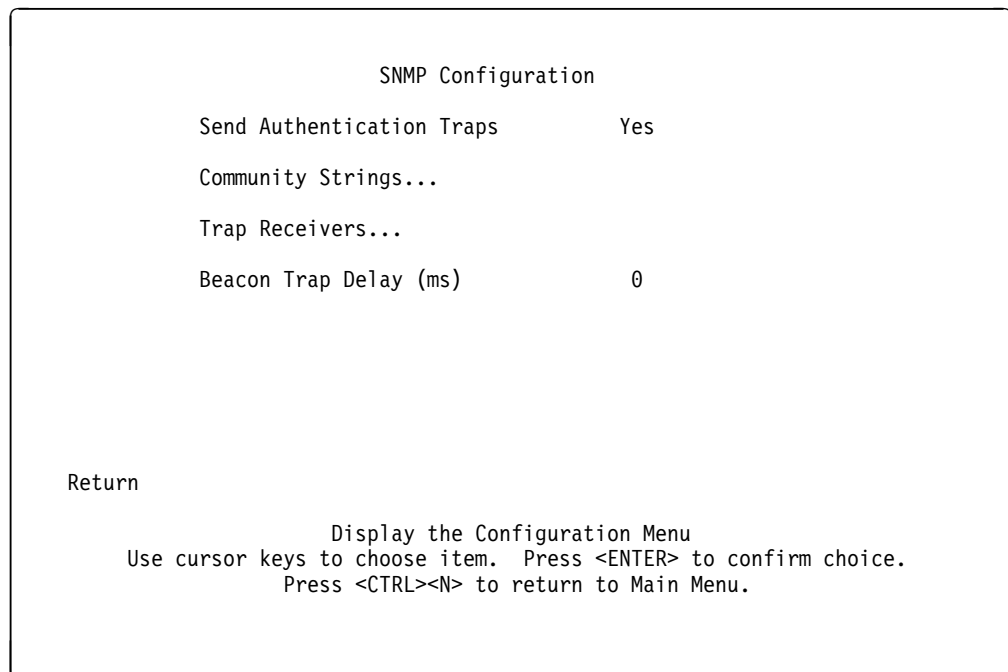

Figure 3-8. SNMP Configuration Menu

Send Authentication Failure Traps

Indicates whether an authentication trap should be issued to Trap Receivers whenever authentication of an SNMP request fails.

The default entry is Yes. Changing it to No blocks all authentication traps from being sent to all trap receivers.

Community Strings Panel

Allows you to display and change the list of community names. Table entries are saved across resets.

Trap Receiver Panel

Displays a table of managers to which to send traps. Entries in the table are saved across resets and power cycles.

Beacon Trap Delay

This timer is used to delay or prevent the sending of beacon traps. When a beaconing condition is detected by the 8270, a timer of the specified duration is started. If the beaconing condition clears before the timer expires, no trap is sent for this beaconing event. If the timer expires or if no delay is specified, the trap is generated and sent to the defined trap receivers (if any trap receivers are defined). The range for this field is 0-300 ms.

Creating Communities

From the SNMP Configuration menu, select **Community Strings...** Use the Community Strings panel to configure the community names for the 8270. A *community name* is a name associated with the 8270 and a set of SNMP managers allowed to manage it with the specified privilege level. Entries are saved when you leave the menu. Figure 3-9 shows sample data.

Community Strings		
<u>Index</u>	<u>Community Name</u>	<u>Mode</u>
1	budget	Read/Write

Return Add Delete Change Clear_Table

Return to previous menu
Use cursor keys to select action. Press <ENTER> to confirm choice.
Press <CTRL><N> to return to Main Menu.

Figure 3-9. Community Strings Panel

- Mode** If you select R (Read), SNMP managers can only view SNMP information. If you select W (Read/Write), SNMP managers can both view and change SNMP information.
- Add** Used to add a community name and access mode.
- Delete** Used to delete a community name.
- Change** Used to modify a community name or access mode.
- Clear Table** Used to delete all community names.

Entries are displayed in the order in which they are entered. There is a limit of 10 community names.

Creating Trap Receivers

From the SNMP Configuration menu, select **Trap Receivers....** Use the Trap Receivers panel to tell the 8270 where to send traps. The trap receivers table contains the IP address of each SNMP manager and a corresponding community name. Entries take effect when you return to the SNMP Configuration menu. Figure 3-10 shows sample data.

Trap Receivers			
Index	IP Address	Community Name	Domain
1	9.67.192.113	budget	Domain01 ...

Return Add Delete Change Clear_Table Zoom

Return to previous menu
Use cursor keys to select action. Press <ENTER> to confirm choice.
Press <CTRL><N> to return to Main Menu.

Figure 3-10. Trap Receivers Panel

Trap messages will be transmitted to the specified IP address on all ports of the selected domains. Traps will be generated for all ports on the switch. However, trap messages will only be transmitted on active ports of the selected domains which have IP enabled.

Use the following tools to set up or change trap receivers entries. The Trap Receivers panel contains a maximum of 13 entries. IP addresses are always entered as a set of four decimal numbers, from 0 through 255. The numbers must be separated by periods.

Note: Trap Receivers addresses are those of the workstations that receive SNMP errors.

Add Used to add a new entry to the Trap Receivers panel.

Delete Used to delete an entry from the Trap Receivers panel.

Change
Used to modify an entry in the Trap Receivers panel.

Clear Table
Used to delete all Trap Receivers panel entries.

Zoom Used to view details about the domain.

Note: When specifying domains use the space bar to select or deselect a domain.

Transparent Bridge Spanning Tree

Enabling the 8270 to participate in Spanning Tree lets you configure redundant (backup) paths in the switch topology, and have the switch automatically disable redundant paths to prevent loops. If the active path is broken and a backup path is available, the switch finds the redundant path and enables it. Without Spanning Tree, a path failure means loss of connectivity for the affected part of the network, and you must manually regain connectivity.

There are two sets of Spanning Tree parameters in the 8270. The following panels configure Spanning Tree for domains that use transparent bridging. See “Internal Source-Route Bridge Configuration” on page 3-34 for source-route bridge Spanning Tree configuration.

From the Configuration Menu, select **Spanning Tree....** Use the Spanning Tree panel to specify whether the 8270 is participating in the Spanning Tree protocol and, if so, to configure Spanning Tree switch and port parameters. These parameters take effect when you exit this menu.

```
Spanning Tree for Domain: default

Change_Displayed_Domain...

Participate in Spanning Tree           802.1d

Switch Priority                         32768

Switch Hello Time (in Seconds)         2

Switch Maximum Message Age (in Seconds) 20

Switch Forward Delay (in Seconds)      15

Port Parameters...

Return

Display the Configuration Menu
Use cursor keys to choose item. Press <ENTER> to confirm choice.
Press <CTRL><N> to return to Main Menu.
```

Figure 3-11. Spanning Tree Panel

The following list defines Spanning Tree parameters:

Change_Displayed_Domain

Choose a new domain to display.

Participate in Spanning Tree

Select **802.1d** or **No**. Select 802.1d to participate in the Spanning Tree protocol. If you select No, the remaining values on the menu are saved but have no effect.

The default is No.

Switch Priority

Enter a priority value for this 8270 in the range of 0 to 65535 (decimal). The lower the priority value, the higher the priority. The bridge or switch with the lowest priority value in a Spanning Tree becomes the root. (To change individual port priorities, select the Port Priority and Port Path Cost menu option.)

The default is 32768.

Switch Hello Time

When this 8270 is the root switch, Switch Hello Time is the time in seconds the switch waits before sending the next configuration message.

The minimum value is 1.

The maximum value is the lower of 10 or:

$(\text{Switch Maximum Message Age}/2) - 1$

The default is 2.

The valid range for this parameter is displayed when you select Switch Hello Time.

Switch Maximum Message Age

Enter the maximum message age used when this 8270 is the root switch. This parameter sets the time in seconds at which the configuration message used by the Spanning Tree algorithm should be discarded.

The minimum value is the larger of 6 or:

$2 \times (\text{Switch Hello Time} + 1)$

The maximum cannot be more than the smaller of 40 or:

$2 \times (\text{Switch Forward Delay} - 1)$

The default is 20.

The range limits that appear when you select this parameter are calculated using the values currently selected for Switch Hello Time and Switch Forward Delay.

Switch Forward Delay

Enter the time in seconds the 8270 waits between transitions from listening to learning, and from learning to forwarding.

The minimum is the larger of 4 or:

$(\text{Switch Maximum Message Age}/2) + 1$

The maximum is 30.

The default is 15.

The lower range limit that appears when you select this parameter reflects the value currently selected for Switch Maximum Age.

Port Parameters

This panel displays a list of port priorities, path costs, and manual modes. This panel is active only when the Participate in Spanning Tree option is set to 802.1d. See "Port Parameters" on page 3-23 for more information.

Port Parameters

From the Spanning Tree panel, select **Port Parameters....** Use the panel to view and change 802.1d Spanning Tree priorities, path costs, and modes for each port. The Spanning Tree uses port path costs to determine which port to select as a forwarding port.

Port Parameters			
Port	Cost	Priority	Manual Mode
1	62	128	MANUAL_FORWARDING
2	62	128	MANUAL_FORWARDING
3	62	128	AUTOMATIC
4	62	128	AUTOMATIC
5	62	128	AUTOMATIC
6	62	128	AUTOMATIC
7	62	128	AUTOMATIC
8	62	128	AUTOMATIC

Return More Change

Return to previous menu
Use cursor keys to choose item. Press <ENTER> to confirm choice.
Press <CTRL><N> to return to Main Menu.

Figure 3-12. Port Parameters Panel

Additional panels are available when you select the More option.

Cost Select the port whose cost you want to change, press **Enter**, and then enter a new value. When the Spanning Tree reconfigures itself, it selects forwarding ports based on the port cost. Therefore, assign lower numbers to ports attached to faster media (such as FDX or TokenPipe), and higher numbers to ports attached to slower media (such as 2400-baud modem links). The possible range is from 1 to 65535. The default is 62. The recommended path cost is:

Path Cost = 1000/LAN speed in Mbps

Priority

Select the port whose priority value you want to change, press **Enter**, and then enter the new value.

Note: The port with the lowest priority value has the highest priority and forwards the Spanning Tree frames.

The possible range is from 0 to 255 (decimal).

The default is 128. If all ports have the same priority value, the port with the lowest number (see the left-hand column in Figure 3-12 on page 3-23) forwards the Spanning Tree frames.

Manual Mode

- **MANUAL_FORWARDING**

Ports which are configured to be manual forwarding will always go directly to forwarding state. Such ports will not participate in the 802.1d spanning tree algorithm.

Note: Ports should only be configured to be manually forwarded when there is no possibility of creating a loop in the network from such a configuration. This would be the case if a directly-attached server is connected to the port. Otherwise, the port should be configured as automatic.

- **AUTOMATIC**

Ports configured this way participate in the 802.1d spanning tree algorithm.

Configuring Token-Ring Ports

From the Configuration Menu, select **Token-Ring Port Configuration....** The Token-Ring Port Configuration panel is shown in Figure 3-13. You can set any of the following parameters for each port on your 8270:

- Switching mode
- State
- Configuration type
 - Auto
 - Fixed
 - Speed
 - Port mode
 - Duplex
- Configuration loss

From the Port Configuration panel, select the **Change** option to set or change port parameters. Figure 3-13 shows sample data for a variety of port configurations.

Notes:

1. Refer to the READ.ME file on the Web at <http://www.networking.ibm.com/support> for the latest information about Token-Ring port configuration.
2. Non-Token-Ring ports are configured using special UFC console panels. In these cases, refer to the documentation shipped with the UFC.

Token-Ring Port Configuration									
Port	Switching Mode	Type	State	Link	Config Type	Speed	Mode	Duplex	Config Loss
2-1	Adaptive	RJ45	Enabled	Down	Auto	RSA16	----	----	8
2-2	Adaptive	RJ45	Enabled	Down	Auto	RSA16	----	----	8
2-3	Cut-Through	RJ45	Enabled	Up	Auto	RSA16	Adapt	Half	8
2-4	Adaptive	RJ45	Enabled	Down	Auto	RSA16	----	----	8
3-1	Adaptive	RJ45	Enabled	Down	Auto	RSA16	----	----	8
3-2	Adaptive	RJ45	Enabled	Down	Auto	RSA16	----	----	8
3-3	Adaptive	RJ45	Enabled	Down	Auto	RSA16	----	----	8
3-4	Adaptive	RJ45	Enabled	Down	Auto	RSA16	----	----	8
4-1	Adaptive	RI/R0	Enabled	Down	Auto	RSA16	----	----	8
4-2	Adaptive	RI/R0	Enabled	Down	Auto	RSA16	----	----	8
5-1	Adaptive	802.5j	Enabled	Down	Auto	RSA16	----	----	8
5-2	Adaptive	802.5j	Enabled	Down	Auto	RSA16	----	----	8

Return More Change

Return to previous menu
Use cursor keys to choose item. Press <ENTER> to confirm choice.
Press <CTRL><N> to return to Main Menu.

Figure 3-13. Token-Ring Port Configuration Panel

Switching Mode

On the Port Configuration panel, enter the switching mode for each port. The default switching mode is Adaptive. The following list explains each available mode:

Cut-Through

The highest-speed switching mode (16 Mbps). You cannot select this mode if the port is set at 4 Mbps.

Store-and-Forward

The mode that provides improved error isolation at the expense of some speed for 16-Mbps ports. Store-and-Forward is the only mode that can be selected for 4-Mbps ports.

Adaptive

The individual ports of an 8270 automatically alternate between Cut-Through and Store-and-Forward mode depending on the specified error threshold. A port operates in Cut-Through mode until the ratio of packets with errors to total packets received on that port reaches the error-rate high threshold set in the Switching Mode Threshold panel (see "Switching Mode Threshold (Token-Ring Ports only)" on page 3-49). The port then changes to Store-and-Forward mode and any packets received with errors will be discarded. The port changes back to Cut-Through mode when the error rate falls below the error-rate low threshold.

Type

The Type column displays the port type. Copper ports are always RJ-45. Ports associated with fiber UFCs may be configured to either RI/RO or 802.5j for the desired signalling method.

State

On the Port Configuration panel, the State column shows and allows you to change port operational status. The default is Enabled. When you disable a port, it will not connect with another switch, access unit, or station. If a port is disabled due to excessive configuration loss (see "Config Loss" on page 3-27), *Cfg Loss* is displayed in this column.

Link

On the Port Configuration panel, the Connect column indicates whether or not the port is connected to a device. Up means that the port is connected (open). Down means that the port is not connected (closed).

Attention: If you change configuration parameters of a connected (Up) port, the port closes and you lose all address information and statistics for that port.

Config Type

On the Port Configuration panel, the Config Type column displays the type of configuration for each port. Use this column to select Auto or Fixed. The default is Auto.

Auto Speed, Mode, and Duplex are automatically set by the 8270.

Fixed Allows you to manually set Speed, Mode, and Duplex.

Note: You must select Fixed to manually set Speed, Mode, or Duplex.

Speed

The Speed column in the Port Configuration panel shows and allows you to set the port speed at 4 or 16 Mbps. The prefix RSA (Ring Speed Adjust) means that the speed was automatically sensed and set by the 8270. The prefix FIX means that the speed was set to a fixed value via configuration.

Note: You must select Config Type as Fixed to manually set Speed.

Mode

From the Port Configuration panel, you can select either Port or Adapter mode for each port, using the Mode column. Selecting Port mode means that only a dedicated connection to a station is supported. The Tx/Rx pinouts are the same as those for a concentrator. Selecting Adapter mode means that the port operates like a station. The connection can be either dedicated or shared. The Tx/Rx pinouts are the same as an adapter's.

Notes:

1. You must select Config Type as Fixed to manually set Mode.
2. When interconnecting optical fiber ports on different switches, one end of the connection must be configured as Adapter and the other end as Port.

Duplex

The Duplex column in the Port Configuration panel displays and allows you to change the duplex mode for each port. The choices are Half or Full. Changes to the duplex settings are made immediately by the 8270.

Note: You must select Config Type as Fixed to manually set Duplex.

Config Loss

Configuration loss occurs when a port link completes a connection (goes up), data traffic is allowed to flow, and the port link subsequently closes (goes down). Use this threshold to control the number of configuration losses that can occur within one minute. When the threshold is exceeded, the port is disabled (Cfg Loss is displayed in the State column) and must be reenabled by using this panel or SNMP.

The Config Loss column in the main Port Configuration panel shows and allows you to change the configuration loss parameters. The default is 8. The range is from 1 to 100.

Configuring Port Address Aging

From the Configuration Menu, select **Address Aging...** Use the Address Aging menu to configure port and master address table aging.

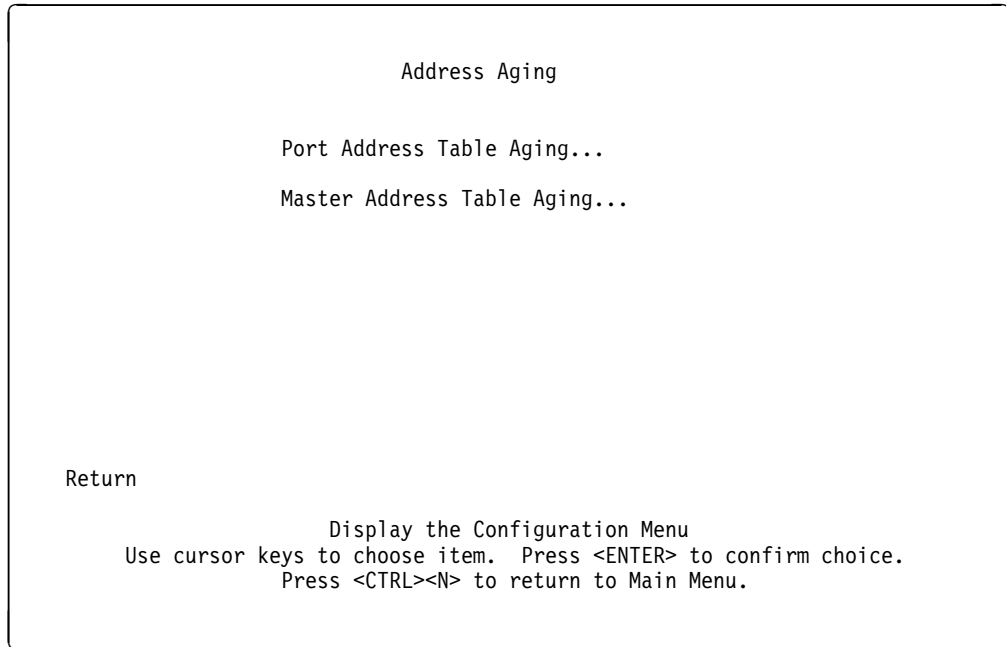

Figure 3-14. Address Aging Menu

Selection of either of the above items takes you the indicated function.

Port Address Table Aging

Use the Port Address Table Aging panel to configure Port address table aging.

Port Address Table Aging		
Port	Aging Time (min.)	Demand Aging Level
2-1	5	90%
2-2	5	90%
2-3	5	90%
2-4	5	90%
3-1	5	90%
3-2	5	90%
3-3	5	90%
3-4	5	90%
4-1	5	90%
4-2	5	90%
4-3	5	90%
4-4	5	90%
5-1	5	90%

Return More Change

Return to previous menu
Use cursor keys to choose item. Press <ENTER> to confirm choice.
Press <CTRL><N> to return to Main Menu.

Figure 3-15. Port Address Table Aging Panel

Aging Time

Defines the time an inactive MAC address remains in the Port Address Table. The default is 5 minutes. A value of 0 causes the port aging time to default to the value of the Master Address Table Aging Time.

Demand Aging Level

When the Port Address Table reaches 100% capacity, a percentage of the addresses equal to

$100\% - \text{Demand Aging Level value}$

are cleared from the table based on a random algorithm that is weighted to clear remote addresses first, until the demand aging level is achieved. The default level is 90%. A level of 90% means that 10% of the addresses are deleted. Valid settings are 90%, 80%, 70%, 60%, 50%, and disabled. A value of disabled means that no addresses are cleared. In this case, when the table becomes full (100% capacity), new addresses cannot be learned.

Master Address Table Aging

Use the Master Address Table Aging Panel to configure Master Address Table aging.

Master Address Table Aging

Aging Time	5
Demand Aging Level	90%

Return

Return to previous menu
Use cursor keys to select action. Press <ENTER> to confirm choice.
Press <CTRL><N> to return to Main Menu.

Figure 3-16. Master Address Table Aging Panel

Aging Time

Defines the value to use for the Port Address Table Aging Time when that time is set to 0.

Demand Aging Level

When the Master Address Table reaches 100% capacity, a percentage of the addresses equal to

$100\% - \text{Demand Aging Level value}$

are cleared from the table based on a random algorithm that is weighted to clear remote addresses first, until the demand aging level is achieved. The default level is 90%. A level of 90% means that 10% of the addresses are deleted. Valid settings are 90%, 80%, 70%, 60%, 50%, and disabled. A value of disabled means that no addresses are cleared. In this case, when the table becomes full (100% capacity), new addresses cannot be learned.

Configuring Source-Routing Capabilities

There are two forms of source-routing in the 8270 – Source-Route Switching and Source-Route Bridging. Source-Route Switching forwards source-routed frames only to ports with the same LAN ID. Source-Route Bridging switches frames among segments with different LAN IDs.

On the 8270, the same LAN ID is used by every port within a domain. By grouping ports together into domains and using source-routing you can confine all traffic to rings with the same LAN ID. However, if you want to permit a work station in one domain to communicate with a work station in another domain, he can enable Source-Route Bridging between those two domains. This permits source-routed frames which originate in one domain but have a target destination another domain, to flow across the 8270. Source-routed frames which have a source and destination within the same domain are not switched across the Source-Route Bridge.

In Figure 3-17, source-routed frames can travel from any domain attached to the internal Source-Route Bridge to any other domain in the internal Source-Route Bridge. For example, a source-routed frame can pass from Domain 1 across the internal Source-Route Bridge to Domain 3. However, in this example, Domain 4 is Source-Route Switched, but is not attached to the internal Source-Route Bridge. Source-routed frames originating in Domain 4 cannot pass into domains 1, 2, or 3.

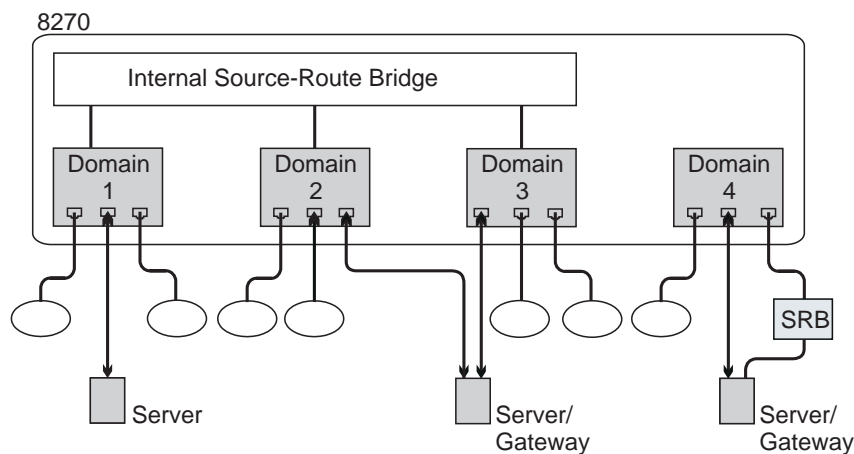

Figure 3-17. Using Internal Source-Route Bridging and Source-Route Switching

The 8270 is made aware of LAN IDs either by learning them from the network or by the user configuring them. In order to learn the local LAN ID, the 8270 must see a source-routed explorer frame from a bridge on any port in the domain. Figure 3-18 on page 3-32 depicts a small network. The local LAN ID is 222, and the 8270 learns this when it sees explorer frames sent through external Bridge B. The 8270 does not *re-learn* its local LAN ID, so if the LAN ID changes (due to network reconfiguration), you must use the Source-Route Configuration utility to either clear the learned LAN ID so a new one can be learned, or to assign a specific LAN ID.

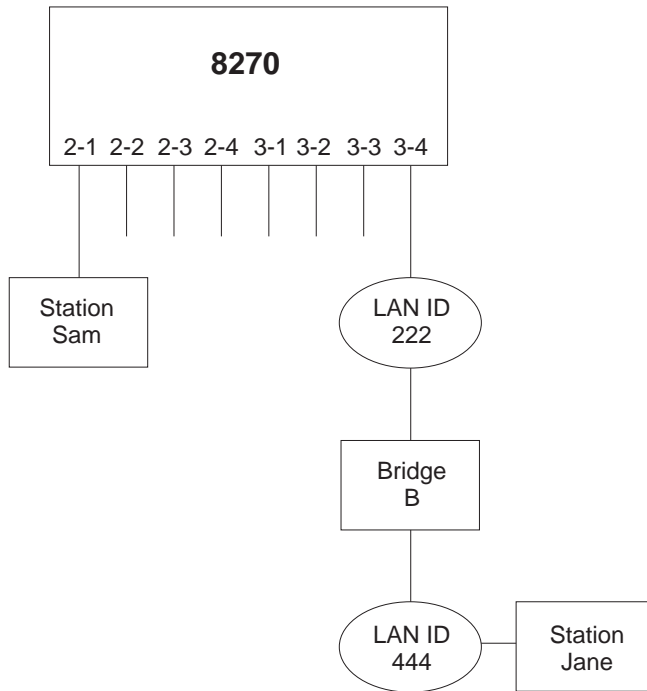

Figure 3-18. Simple External Source-Route Bridged Network

In connection with source-routing and the 8270, several equivalent terms are used both in IBM and the LAN industry in general. For the purposes of this manual, the following terms are used interchangeably as indicated:

LAN ID = LAN segment number = ring number

LAN segment = Domain

Assigning or Changing LAN Segment Numbers

To assign or change the LAN segment numbers associated with each domain, select **Source-Route Configuration...** from the Configuration Menu. The Source-Route Configuration panel is shown in Figure 3-19.

```
Source-Route (SR) Configuration - Internal SR Bridge is disabled

-----Ports-----
Index  Domain      LAN Segment Number  Slot2 Slot3 Slot4 Slot5 Slot6
-----|-----|-----|-----|-----|-----|-----|
1      default    Unknown             XXXX  .XX.  .XXX  .XXX  XXXX
2      Domain01   001                 ....  X...  ....  ....  ....
3      Domain02   * 222                ....  ...X  ....  ....  ....
4      Domain03   002                 ....  ....  X...  ....  ....
5      Domain04   * 123                ....  ....  ....  X...  ....

* = Learned LAN Segment Number
# = LAN Segment enabled for SR Bridging
Return More Assign_LAN_Segment_Number Configure_Internal_SR_Bridge

Return to previous menu
Use cursor keys to choose item. Press <ENTER> to confirm choice.
Press <CTRL><N> to return to Main Menu.
```

Figure 3-19. Source-Route Configuration Panel

Select **Assign LAN Segment Number** to assign or change the LAN Segment Number (sometimes referred to as the *Ring Number*) or to reset the number to an *unknown* state. In an unknown state, the 8270 learns the segment number from source-routed explorer frames. If the segment is enabled for source-route bridging, this value cannot be changed or removed. A domain must have a segment number in order to be enabled for source-route bridging.

Select **Configure Internal SR Bridge** to bring up the internal source-route bridge (SRB) configuration menu. If the number of learned or assigned segments is less than two, an error is displayed since you cannot source-route bridge with less than two segments. You must have two or more segments with known segment numbers to get to the source-route bridge menu.

The default for LAN Segment Number is unknown.

Use the Return option to return to the Configuration Menu.

Entries and changes take effect immediately.

Notes:

1. Port columns for which no port exists contain blanks.
2. Ports that exist but do not have the indicated LAN segment number in their table contain a period (.).
3. Ports that exist and have the indicated LAN segment number in their table contain an X.

Internal Source-Route Bridge Configuration

To set global parameters for the internal source-route bridge function, select **Configure_Internal_SR_Bridge** from the Source-Route (SR) Configuration panel.

Internal Source-Route Bridge (SRB) Configuration

Bridge Number (hex)	1
LAN Segment Bridging Parameters...	
SRB Spanning Tree Configuration ...	
Internal Bridge Enabled?	Disabled

Return

Return to previous menu
Use cursor keys to choose an item. Press <ENTER> to confirm your choice.
Press <CTRL><N> to return to Main Menu.

Figure 3-20. Internal Source-Route Bridge Configuration Menu

Bridge Number

Specify the internal bridge number to be used in source-route descriptors. The range is from 0 to F, with a default of 1. The internal bridge must be disabled to change the value of this field.

LAN Segment Bridging Parameters

Change the internal bridging parameters for individual LAN segments. Selecting this option leads to a new panel.

SRB Spanning Tree Configuration

Configure the source-route bridge to use automatic or manual Spanning Tree. Selecting this option leads to a new panel.

Internal Bridge Enabled

Enable or Disable the internal source-route bridge function. Changes to this parameter take effect immediately, so a confirmation message is issued when the source-route bridge state is changed. If there are fewer than two segments enabled for bridging, an error message is displayed, and the change does not take effect.

Displaying LAN Segment Bridging Parameters

To set source-route bridge parameters for individual LAN segments, select **LAN Segment Bridging Parameters...** from the Internal Source-Route Bridge (SRB) Configuration menu. On this panel, all LAN segments with learned or assigned segment numbers are displayed.

LAN Segment Bridging Parameters								
Index	Segment		Bridged Segment	--ARE Frames--		--STE Frames--		Max Frame Size
	Number	Domain Name		Tx Hop Count	Rx Hop Count	Tx Hop Count	Rx Hop Count	
1	001	domain01	disabled	7	7	7	7	4472
2	002	domain03	disabled	7	7	7	7	4472
3	123	domain04	disabled	7	7	7	7	4472
4	222	domain02	disabled	7	7	7	7	4472

Return More Change

Return to previous menu
Use cursor keys to choose an item. Press <ENTER> to confirm your choice.
Press <CTRL><N> to return to Main Menu.

Figure 3-21. LAN Segment Bridging Parameters Panel

Change Change the internal bridging parameters for a LAN segment. Selecting this option leads to a new panel.

Changing LAN Segment Bridging Parameters

To change LAN segment bridging parameters, select **Change** from the LAN Segment Bridging Parameters panel.

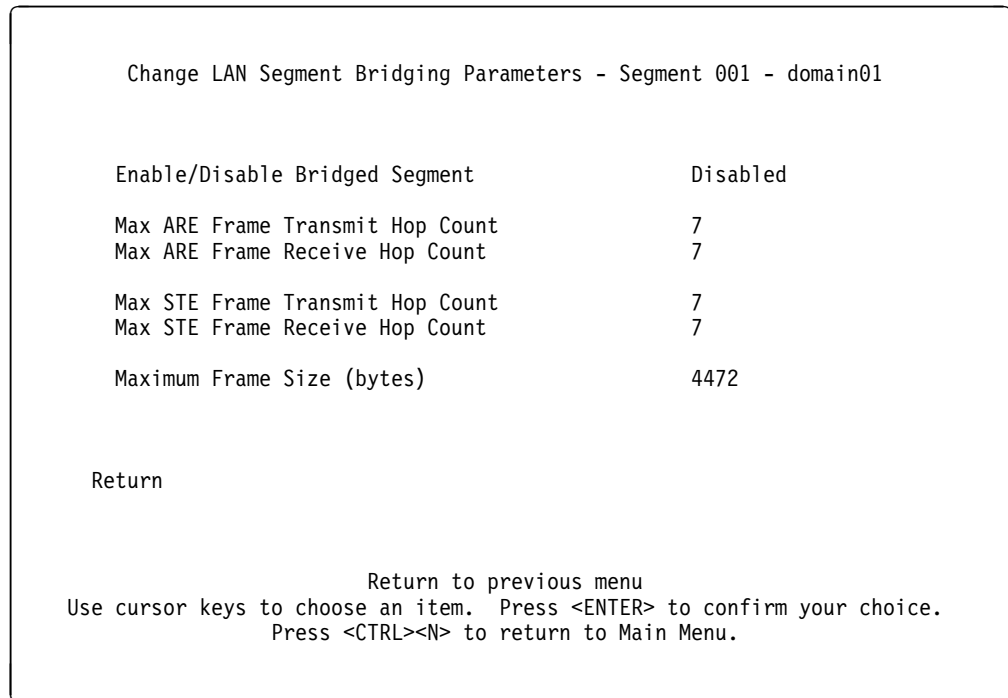

Figure 3-22. Change LAN Segment Bridging Parameters Panel

Enable/Disable Bridged Segment

Enable or disable frame forwarding for this segment over the internal bridge.

Max ARE Frame Transmit Hop Count

Change the All-Routes Explorer (ARE) transmit hop count for this segment. The range is from 1 to 13, with a default of 7.

Max ARE Frame Receive Hop Count

Change the All-routes Explorer (ARE) receive hop count for this segment. The range is from 1 to 13, with a default of 7.

Max STE Frame Transmit Hop Count

Change the Spanning Tree Explorer (STE) transmit hop count for this segment. The range is from 1 to 13, with a default of 7.

Max STE Frame Receive Hop Count

Change the Spanning Tree Explorer (STE) receive hop count for this segment. The range is from 1 to 13, with a default of 7.

Maximum Frame Size

Change the maximum frame size for frames forwarded on this segment. Values that may be selected are 4472, 2052, 1500, or 516. This value is used by end stations to determine the largest frame size for the network. The default is 4472.

Note: The maximum frame size values allowed in the 1525 MIB are the IEEE values of 4399, 2052, 1470, and 516 – two of which are different from the IBM values defined above. The 8270 always uses the larger IBM values. When retrieving this setting using SNMP, the smaller IEEE value is returned even if the larger IBM value was set through the console. This is not an error.

Source-Route Bridge Spanning Tree Configuration

To change the Spanning Tree parameters for source-route bridging, select **SRB Spanning Tree Configuration...** from the Internal Source-Route Bridge (SRB) Configuration menu.

Note: The Source-Route Bridge Spanning Tree parameters are in addition to and independent of the Spanning Tree parameters for transparent domains found in “Transparent Bridge Spanning Tree” on page 3-21.

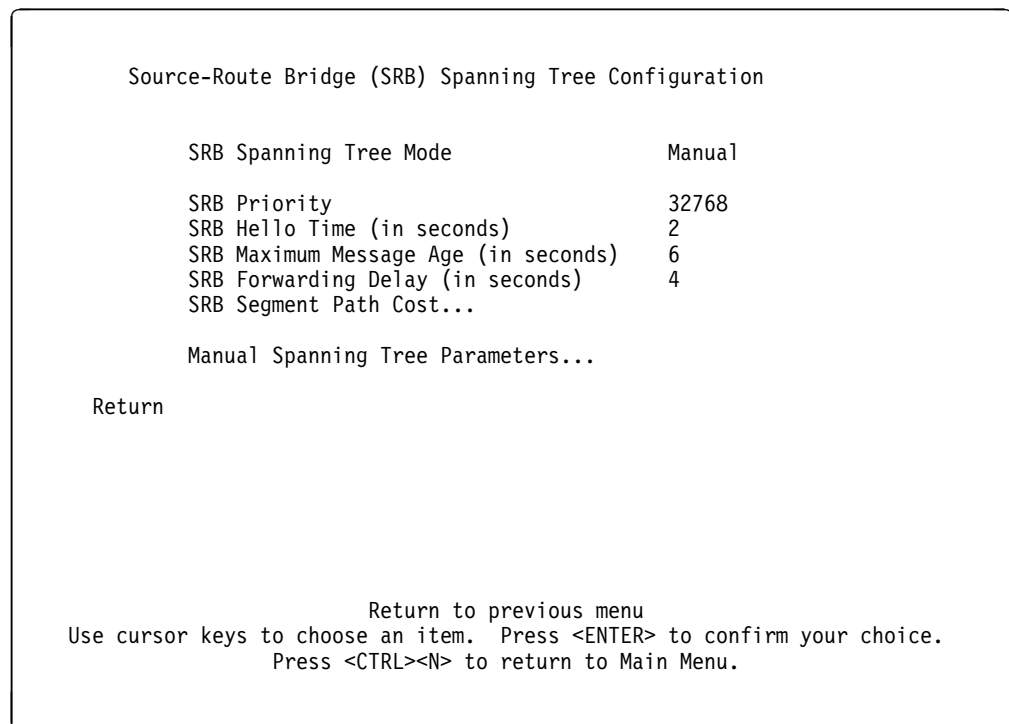

Figure 3-23. Source-Route Bridge Spanning Tree Configuration Panel (1 of 2)

SRB Spanning Tree Mode

Set the mode to Automatic or Manual. Automatic mode allows the internal source-route bridge to participate in the source-route spanning tree algorithm with other source-route bridges to determine a single route through the source routing network for Spanning Tree explorer (STE) frames. Manual mode allows the user to specify which logical bridge ports are forwarding the STE frames. The default mode is manual.

SRB Priority

This option can be changed only when the Spanning Tree Mode is Automatic. The SRB priority becomes part of the Bridge ID for the spanning tree algorithm. The lower the priority value, the higher the priority. The source-route bridge with the highest priority in a Spanning Tree becomes the root. The range is from 0 to 65535, with a default of 32768.

SRB Hello Time

This option can be changed only when the Spanning Tree Mode is Automatic. This parameter determines the time in seconds between source-route Spanning Tree configuration messages when this bridge is the root. The minimum is 1. The maximum is the lower of 10 or

$(\text{SRB Maximum Message Age}/2) - 1$.

The default is 2.

SRB Maximum Message Age

This option can be changed only when the Spanning Tree Mode is Automatic. This parameter sets the time in seconds at which the configuration message used by the source-route Spanning Tree algorithm should be discarded when this bridge is the root. The minimum value is the higher of 6 or

$2 \times (\text{Bridge Hello Time} + 1)$.

The maximum value is the lower of 40 or

$2 \times (\text{Switch Forward Delay} - 1)$.

The default is 6.

SRB Forwarding Delay

This option can be changed only when the Spanning Tree Mode is Automatic. This parameter controls the time in seconds that a bridge spends in the listening state when this bridge is the root. The minimum is the larger of 4 or

$(\text{Switch Maximum Message Age}/2) + 1$.

The maximum is 30. The default is 4.

SRB Segment Path Cost...

This option can be selected only when the Spanning Tree Mode is Automatic. Selecting this option leads the panel shown in Figure 3-24 on page 3-40.

Manual Spanning Tree Parameters...

This is the only option that can be selected on this panel when Spanning Tree mode is manual. Selecting this option leads to the panel shown in Figure 3-25 on page 3-41.

Source-Route Bridge Path Cost

To change the path cost for a source-route bridge segment, select **SRB Segment Path Cost...** from the Source-Route Bridge (SRB) Spanning Tree Configuration panel.

Source-Route Bridge (SRB) Path Cost			
<u>Index</u>	<u>Segment Number</u>	<u>Domain Name</u>	<u>Segment Path Cost</u>
1	001	domain01	62
2	002	domain03	62
3	222	domain02	62

Return More Change Segment Path Cost

Return to previous menu
Use cursor keys to choose an item. Press <ENTER> to confirm your choice.
Press <CTRL><N> to return to Main Menu.

Figure 3-24. Source-Route Bridge Path Cost Panel

Change Segment Path Cost

Path cost is used by the source-route Spanning Tree algorithm to determine which logical bridge ports (LBPs) are in forwarding state for STE frames. The range is from 1 to 65535, with a default of 62.

Source-Route Bridge (SRB) Manual Spanning Tree Parameters

To manually change the forwarding state for a source-route bridge segment, select **Manual Spanning Tree Parameters...** from the Source-Route Bridge (SRB) Spanning Tree Configuration panel.

Note: Changes made to this panel are not effective if the SRB Spanning Tree Mode is set to Automatic.

Source-Route Bridge (SRB) Manual Spanning Tree Parameters			
<u>Index</u>	<u>Segment Number</u>	<u>Domain Name</u>	<u>Single-route Bcast Frames</u>
1	001	domain01	Forward
2	002	domain03	Forward
3	222	domain02	Forward

Return More Change Single-Route Bcast Frame State

Return to previous menu
Use cursor keys to choose an item. Press <ENTER> to confirm your choice.
Press <CTRL><N> to return to Main Menu.

Figure 3-25. Source-Route Bridge Manual Spanning Tree Parameters Panel

Change Single-Route Bcast Frame State

Each segment is set to Forward or Block STE frames. The default is Forward.

Changing Address Filters and Port Security (Token-Ring Ports only)

From the Configuration Menu, select **MAC Filter & Port Security...** Use the MAC Filter & Port Security menu shown in Figure 3-26 to configure MAC address filters, configure port security attributes, or view port filters. A filter for a particular MAC address can be applied to only one domain.

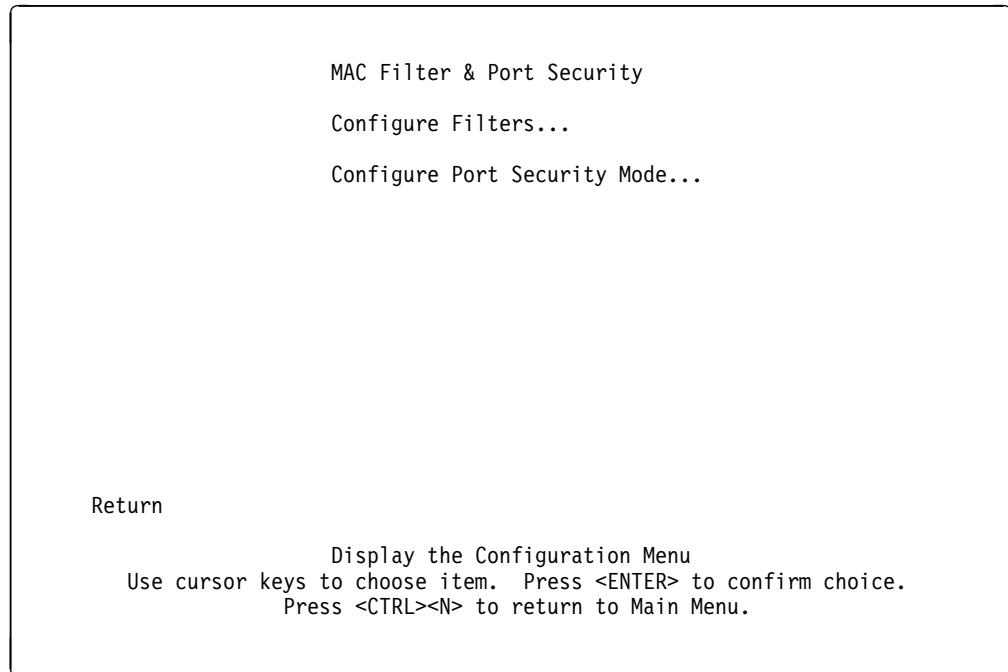

Figure 3-26. MAC Filter & Port Security Menu

Note: Filters are applicable only to segments that begin and end at the 8270

Configuring Filters

From the MAC Filter & Port Security menu, select **Configure Filters....** Use the Configure Filters panel to restrict certain users from communicating with other users by specifying up to 100 source or destination MAC addresses to be filtered at the port of entry into the 8270. MAC addresses can be unicast, multicast (group), or broadcast. All 100 addresses can be associated with one port or divided among the ports. Figure 3-27 shows sample data.

Configure Filters				
<u>Index</u>	<u>MAC Address</u>	<u>Type</u>	<u>Entry Ports</u>	<u>Exit Ports</u>
1	10005A 4315CF	Block src	2-1 2-2 2-3 ...	
2	10005A 4975AC	Block dst	4-1	
3	10005C 4315CF	Allow src	4-1	6-1
4	10005A 431525	Force dst	4-1	6-1

Filter Type:
Block any packet with Source Address from ports....
Block any packet with Destination Address from ports....
Allow any packet with the designated Source Address to port(s)....
Force any packet with the designated Destination Address to port(s)....

Return More Add Delete Change Clear_Table Zoom

Return to previous menu
Use cursor keys to choose item. Press <ENTER> to confirm choice.
Press <CTRL><N> to return to Main Menu.

Figure 3-27. Filter Configuration Panel

The following list describes functions available on the Configure Filters panel:

Add Used to specify the filter type, the MAC address you want to filter, and the entry ports to which this filter is applied. Leaving entry port parameters empty causes a filter to be applied to all ports. A filter for a particular MAC address can be applied to only one domain.

Delete Used to specify a filter you want to remove.

Clear_Table

Clears the address table.

Zoom Displays the complete list of Entry and Exit ports for the filter.

Filter Type:

- Block any packet with Source Address from ports....
Listed as Block src in the Type field.
- Block any packet with Destination Address from ports....
Listed as Block dst in the Type field.
- Allow any packet with the designated Source Address to port(s)....
Listed as Allow src in the Type field.
- Force any packet with the designated Destination Address to port(s)....
Listed as Force dst in the Type field.

When you choose any of the filter Type options, you are prompted to enter the port to which the filter applies. This is the port where the filtering takes place. After you have entered it, this port number appears in the Applied Ports column.

When you choose Allow any packet with the designated Source address to port(s) or Force any packet with the designated Destination Address to port(s), you are also prompted to enter the port that is to receive the filtered data. This port appears in the Exit Ports column.

Notes:

1. If you set up a filter for broadcast packets, hosts on the other side of the 8270 do not see the ARP broadcast packets.
2. If a filter is set up with the TokenPipe option, filters must be created for all ports in the TokenPipe.
3. The Allow and Force type filters should be used in conjunction with port security configuration. See "Configuring Port Security Mode" on page 3-45.

Configuring Port Security Mode

From the MAC Filter & Port Security menu, select **Configure Port Security Mode...** Use the Configure Port Security Mode panel to define the security attributes of each port. This function totally blocks (secures) all addresses at selected ports unless a MAC filter allows them. Addresses that have been allowed or forced by a configured filter are not blocked. Figure 3-28 shows sample data.

Configure Port Security Mode	
Port	Security Mode
2-1	Normal
2-2	Normal
2-3	Normal
2-4	Normal
3-1	Normal
3-2	Normal
3-3	Normal
3-4	Normal
4-1	Normal
4-2	Normal
4-3	Normal
4-4	Normal
5-1	Normal

Return More Change

Return to previous menu
Use cursor keys to choose item. Press <ENTER> to confirm choice.
Press <CTRL><N> to return to Main Menu.

Figure 3-28. Configure Port Security Mode Panel

The following list describes functions available on the Configure Port Security Mode panel:

Normal No security mode is defined for a port. This is the default.

Secure source addresses

Block all source addresses, except those allowed by a configured filter.

Secure destination addresses

Block all destination addresses, except those forced by a configured filter.

Secure both source and destination addresses

Block all source and destination addresses, except those allowed or forced by a configured filter.

Configuring TokenProbe (Token-Ring Ports only)

You can configure any one of the Token-Ring ports as the TokenProbe port. By attaching a network analyzer to the TokenProbe port, you can then monitor the switched traffic of a selected port.

To use TokenProbe, select **TokenProbe Configuration...** from the Configuration Menu. Enter the number of the port you want to configure as the TokenProbe port, and also the number of the port you want to monitor.

TokenProbe Configuration	
TokenProbe Port Number	2-2
Port to Monitor	2-1
Monitor Local Traffic	No

Return

Display the Configuration Menu
Use cursor keys to choose item. Press <ENTER> to confirm choice.
Press <CTRL><N> to return to Main Menu.

Figure 3-29. TokenProbe Configuration Panel

TokenProbe is helpful when analyzing traffic on adapters or devices attached directly to a switch port, and there is no LAN hub or concentrator port to help with tracing the segment.

With a trace tool, such as an IBM DatagLANce adapter, attached to the configured TokenProbe port, you can monitor switch port traffic.

The following list provides definitions for items appearing on the TokenProbe Configuration panel:

TokenProbe Port Number

Allows you to select the port to which the network analyzer will be attached. Select port 0 to disable the TokenProbe function. A port that has been designated as the TokenProbe port should be set to the default state (TokenProbe disabled) when it is returned to normal service as a switch port.

Port to Monitor

Allows you to select the port that will be monitored by the TokenProbe port.

Monitor Local Traffic

This parameter determines the type of frames monitored on the port. When set to Yes, all non-MAC frames are monitored whether or not they pass through the 8270. When set to No, only frames that pass through the 8270 to and from the monitored port are monitored.

Configuring TokenPipe (Token-Ring Ports only)

You can configure two to four ports connected between 8270s to create TokenPipe, 16-Mbps links. This increases the capacity of the connection between 8270s to support up to 64-Mbps HDX or 128-Mbps FDX.

To use TokenPipe, select **TokenPipe Configuration...** from the Configuration Menu.

TokenPipe Configuration		
TokenPipe	State	Ports
1	Down	2-1 2-2
2	N/A	Not Defined
3	N/A	Not Defined
4	N/A	Not Defined

Return Add Delete Change Clear_Table

Return to previous menu
Use cursor keys to choose item. Press <ENTER> to confirm choice.
Press <CTRL><N> to return to Main Menu.

Figure 3-30. TokenPipe Configuration Panel

State

- N/A — Ports have not been defined for a TokenPipe.
- Down — A TokenPipe has been defined but physical cable connections have not yet been established.
- Up — A TokenPipe is defined and operational.

Ports Defines the ports participating in the TokenPipe.

Note: Create TokenPipe port connections between 8270s in consecutive, numeric order from lowest- to highest-numbered port. The lowest-numbered port becomes the primary port and all broadcast frames flow through this port as TokenPipe connections are created and then assigned to the other TokenPipe ports.

When defining a TokenPipe, ensure that both ends of each interconnected pair have compatible configuration. The suggested configuration is **auto** for configuration type, and **fix16** for Speed. See “Configuring Token-Ring Ports” on page 3-25.

Switching Mode Threshold (Token-Ring Ports only)

From the Configuration Menu, select **Switching Mode Threshold...** Use the Switching Mode Threshold panel to change the error-rate thresholds, trend, and sample period.

Note: Switching Mode Threshold only applies when the port is in Adaptive mode.

Switching Mode Threshold

Error rate high threshold	10
Error rate low threshold	1
Error rate trend	1
Error rate sample period	10

Return

Return to previous menu
Use cursor keys to choose item. Press <ENTER> to confirm choice.
Press <CTRL><N> to return to Main Menu.

Figure 3-31. Switching Mode Threshold Panel

The following list defines functions available on the Switching Mode Threshold panel:

Error rate high threshold

When the port is set to Adaptive mode, the error-rate high threshold is one of two criteria used to automatically force the port from Cut-Through mode to Store-and-Forward mode. If the percentage of errors detected in a sampling period exceeds the high threshold, the port is forced from Cut-Through mode to Store-and-Forward mode. The range of the high threshold is 1–100%. The default is 10%.

Error rate low threshold

When the port is set to Adaptive mode, the error-rate low threshold is one of two criteria used to automatically return the port from Store-and-Forward mode to Cut-Through mode. If the percentage of errors detected in a sampling period falls below the low threshold, then the port is returned from Store-and-Forward mode to Cut-Through mode. The low threshold ranges from 1–100%. The default is 1%.

Error rate trend

When the port is set to Adaptive mode, the error-rate trend is one of two criteria used to force the port from Cut-Through to Store-and-Forward. It is also one of two criteria used to return the port from Store-and-Forward to Cut-Through mode. The error-rate trend, which is the difference

between two successive sampling periods, is compared to the trend threshold. If the percentage of errors has increased between two sampling periods, and the trend exceeds the trend threshold, then the port is forced from Cut-Through mode to Store-and-Forward mode. However, if the percentage of errors has decreased between two sampling periods, and the trend exceeds the trend threshold, then the port is returned from Store-and-Forward mode to Cut-Through mode. The error-rate trend algorithm is active only when the error rate is between the error rate high threshold and the error rate low threshold. The error-rate trend threshold ranges from 1% to 100%. The default is 1%.

Error Rate Sample Period

The Error Rate Sample Period defines the duration of the sample period in seconds for ports in Adaptive Mode.

The range is from 5 to 120 seconds, with a default of 10 seconds. The error rate is computed on a per port basis for received packets (inbound to the port) as the ratio of the number of packets with errors to the total number of packets for the sample period.

Password

From the Configuration Menu, select **Password....** Use the Password panel to add, change, or delete the Read/Write or the Read Only password. If you establish a Read/Write password, users must enter one of the defined passwords to obtain access to the Main Menu. When a Read Only password has been entered at the Copyright panel, menu function is limited to viewing:

- ATM LEC statistics and status
- All menus in the Status/Statistics menu

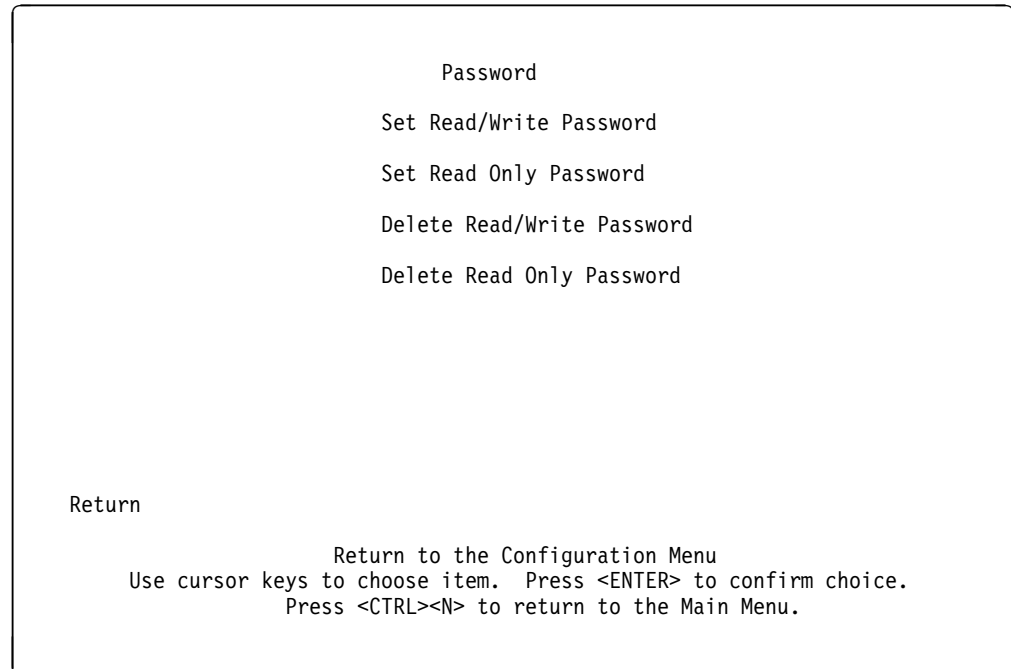

Figure 3-32. Password Panel

Set Read/Write Password

Used to establish or change the Read/Write password. The default is no password.

Set Read Only Password

Used to establish or change the Read Only password. A Read Only password can be defined if a Read/Write password has already been defined. The default is no password.

Delete Read/Write Password

Used to delete the Read/Write password.

Delete Read Only Password

Used to delete the Read Only password.

The system prompts you to enter the password before it allows you to change or delete the password. If you are establishing a new password, press **Enter** at the Old Password prompt.

The password is saved across resets and power cycles.

Note: If you have forgotten your password, press the **System Request** button to access the System Request Menu, and then select **Clear NVRAM**. This clears the password but also sets all configuration parameters to their default values, clearing any values you have entered.

Console Configuration

From the Configuration Menu, select **Console Configuration**. Use the Console Configuration menu to configure for a serial link or Telnet console session and to set the console timeout value.

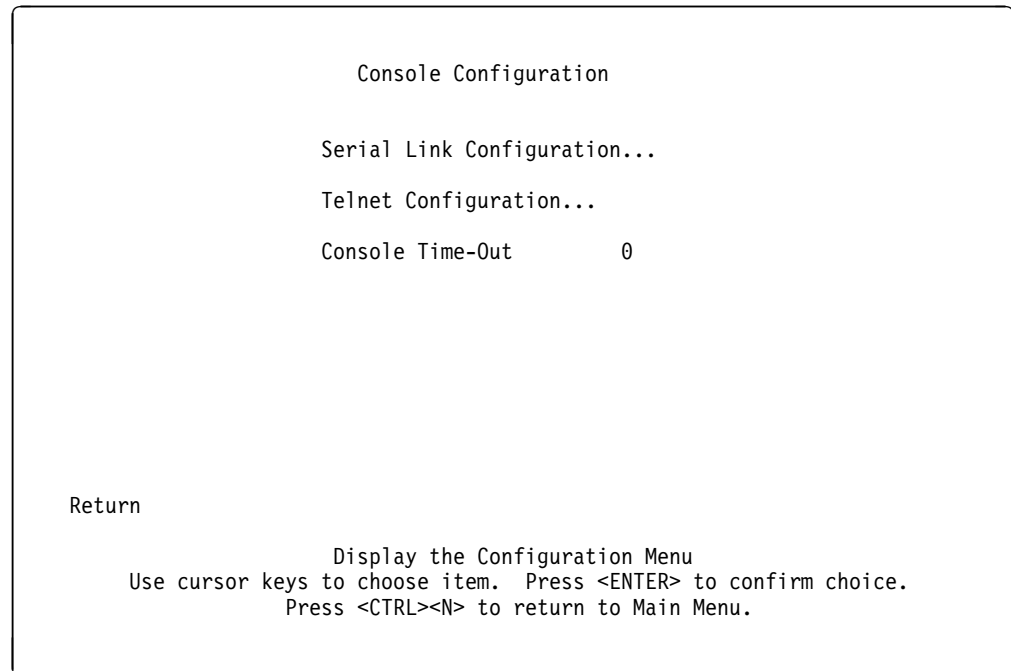

Figure 3-33. Console Configuration Menu

The following list describes functions available from the Console Configuration menu:

Serial Link Configuration

Used to configure a console session with a device attached to the EIA 232 port.

Telnet Configuration

Used to configure a console session via Telnet.

Console Time-Out

Used to set the number of minutes a console session remains idle before timing out. Unsaved screen entries are lost when the console times out. The default is 0, meaning that a timeout will not occur.

Serial Link Configuration

From the Console Configuration menu, select **Serial Link Configuration....** Use the Serial Link Configuration panel to change the default parameters of the EIA 232 port and, if necessary, to set up a console session with an attached device.

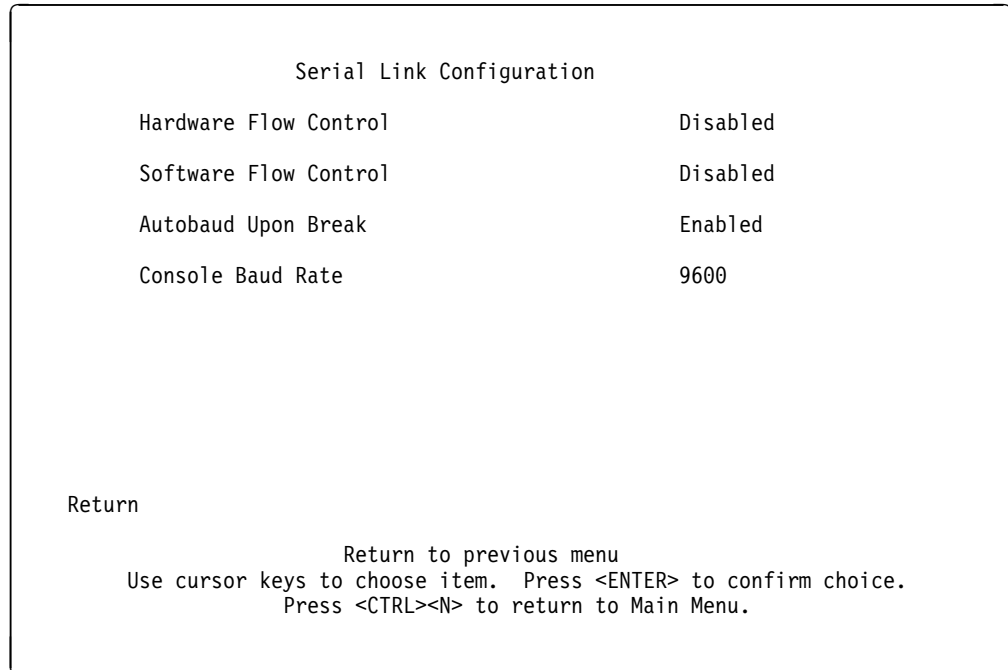

Figure 3-34. Serial Link Configuration Panel

The following list defines functions available on the Serial Link Configuration panel:

Hardware Flow Control

Used to enable or disable hardware flow control. The default is Disabled. Some emulators might drop console sessions after an extended period of time if this is enabled.

Software Flow Control

Used to enable or disable software flow control. The default is Disabled.

Autobaud Upon Break

Used to enable or disable autobaud upon break. The default is Enabled. When set to enabled, a baud rate change can be accomplished by changing the baud rate of the terminal emulator, disconnecting and reconnecting the EIA 232 cable, and then pressing Enter until a panel appears.

Note: This feature should not be disabled in most environments.

Console Baud Rate

Used to display and change the 8270 EIA 232 port baud rate.

Acceptable values are 1200, 2400, 4800, 9600, 19200, 38400, and 57600.

The default value is 9600.

Make sure that your terminal emulator baud rate matches the console baud rate you set.

Telnet Configuration

From the Console Configuration menu, select **Telnet Configuration....** Use the Telnet Configuration panel to configure the 8270 for a Telnet console session. Make sure that the Telnet client terminal type is set to VT100, VT102, or VT220.

```

                                Telnet Configuration
Number of Telnet Sessions Allowed      5
Disallow New Telnet Session           No
Terminate All Active Telnet Sessions
Telnet Sessions...

Return

                                Return to previous menu
                                Use cursor keys to choose item. Press <ENTER> to confirm choice.
                                Press <CTRL><N> to return to Main Menu.
```

Figure 3-35. Telnet Configuration Panel

The following list describes functions available on the Telnet Configuration panel:

Number of Telnet Sessions Allowed

Defines the number of Telnet sessions allowed. The default is 5.

Disallow New Telnet Sessions

Disallows new Telnet sessions. The default is No.

Terminate All Active Telnet Sessions

Stops all active Telnet sessions.

Telnet Sessions

Displays any active Telnet sessions.

Telnet Sessions

From the Telnet Configuration panel, select **Telnet Sessions....** Use the Telnet Sessions panel to display or close any active Telnet sessions.

Telnet Sessions						
Index	Box	--- Remote ---		--- Local ---		Status
		IP	Port	IP	Port	
1	1	98.68.214.153	1493	9.70.199.118	23	Open

Return Close_Session

No active Telnet session. Press any key to continue...
Return to previous menu
Use cursor keys to choose item. Press <ENTER> to confirm choice.
Press <CTRL><N> to return to Main Menu.

Figure 3-36. Telnet Sessions Panel

Chapter 4. Monitoring the 8270

This chapter provides information about monitoring 8270 activity using a console interface. Before proceeding with the information in this chapter, make sure that you have attached a PC or other DTE device to the EIA 232 port on the 8270. For information on attaching a local or remote device, refer to the *8270 Installation and Service Guide*.

Should you need to reconfigure parameters for the 8270, go to Chapter 3, "Configuration" for specific instructions.

To view status or statistics, select **Status/Statistics...** from the Main Menu (see Figure 3-2 on page 3-9).

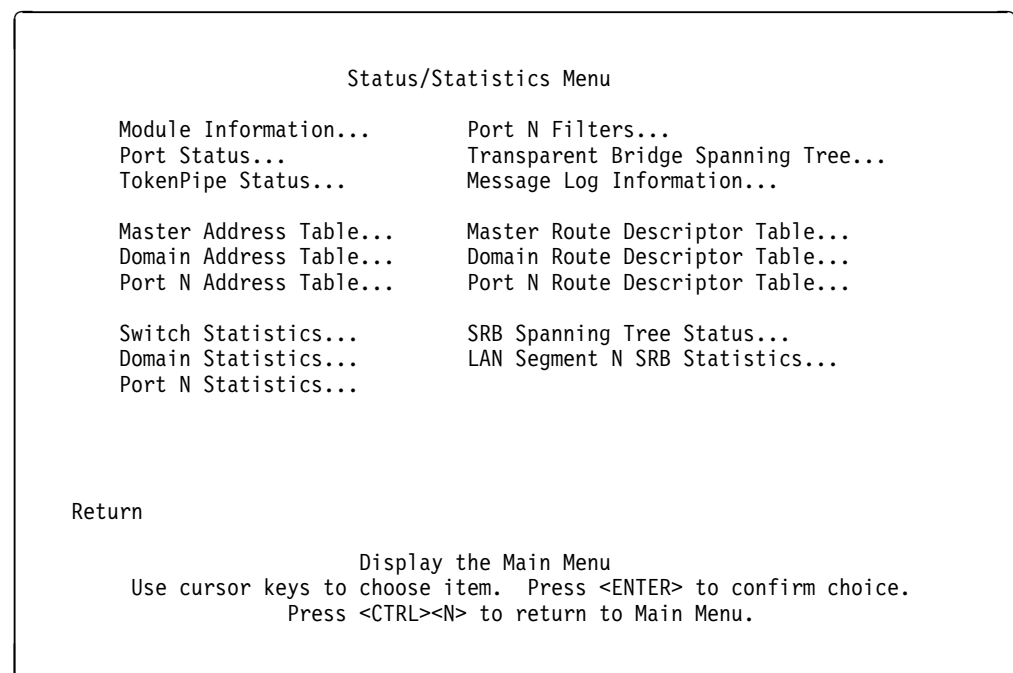

Figure 4-1. Status/Statistics Menu

Viewing Module Information

From Status/Statistics Menu, select **Module Information...** Use the Module Information panel to display information about installed UFCs.

Module Information					
Module	Status	Type	Revision	Ports	Up Time
0	up	Processor	0	0	17:50:36
1	up	TR Fiber	0	2	17:50:36
2	up	TR UTP/STP	0	4	17:50:36
3	up	TR UTP/STP	0	4	17:50:36
4	up	TR UTP/STP	0	4	17:50:36
5	empty				
6	empty				
7	empty				
8	empty				

Return

Return to previous menu
Use cursor keys to choose item. Press <ENTER> to confirm choice.
Press <CTRL><N> to return to Main Menu.

Figure 4-2. Module Information Panel

The following list describes information available on the Module Information panel:

Module Displays a module number. Installed UFCs will appear as 1 through 8 for 8270-800 and 1 through 6 for 8270-600.

Status Indicates whether the module is up or down.

Type Indicates the type of module or UFC.

Revision
Displays the revision level of the module.

Ports Indicates the number of ports on the module.

Up Time
Displays time since the 8270 was last reset.

Viewing the Master Address Table

From the Status/Statistics Menu, select **Master Address Table....** Use the Master Address Table shown in Figure 4-3 to view the station addresses of all ports known to the 8270. The table can contain up to 10 000 entries.

Master Address Table									
MAC Address		Local Port	Ports - Filtered Ports High-Lighted						
			Slot2	Slot3	Slot4	Slot5	Slot6		
			1234	1234	1234	1234	1234		
0004AC	281320	Swch Base	XXXX	XX..	XXXX	XXXX	XXXX		
0004AC	281340	default	XXXX	XX..	XXXX	XXXX	XXXX		
0004AC	281580	2-4	...X		
0004AC	281587	2-4	...X		
0004AC	294540	Unknown	...X		
0004AC	318F58	2-4	...X		
0004AC	358001	2-4	...X		
0004AC	36910A	2-4	...X		
0004AC	372A1A	2-4	...X		
0004AC	542CB9	2-4	...X		
0004AC	54BCF6	2-4	...X		

Return More Search View Logical Ports

Return to previous menu
Use cursor keys to choose item. Press <ENTER> to confirm choice.
Press <CTRL><N> to return to Main Menu.

Figure 4-3. Master Address Table Panel

The following list describes information shown on the Master Address Table:

MAC Address

Displays the MAC address of a node.

Local Port

The port where this MAC address was received as a source address, or unknown if it has only been received as a destination address. This field will also identify addresses internal to the switch, as well as permanent multicast addresses.

Ports Displays the ports whose address tables include this MAC address.

Notes:

1. Port columns for which no port exists contain blanks.
2. Ports that exist but do not have the indicated MAC address in their address table contain a period (.).
3. Ports that exist and have the indicated MAC address in their address table contain an X.

Viewing the Master Route Descriptor Table

From the Status/Statistics Menu, select **Master Route Descriptor Table...** Use the Master Route Descriptor Table to view the route descriptors that have been learned by the 8270 and the associated ports. These descriptors are contained within the 10000 entries allowed for the Master Address Table. They appear on this menu sorted by route descriptor (as if it were one large number).

Master Route Descriptor Table						
Route Descriptor	Local Port	Ports:				
		Slot2 1234	Slot3 1234	Slot4 1234	Slot5 1234	
D29:1:016	2-3	..X.	
D29:1:017	2-3	..X.	
D29:1:018	2-3	..X.	
D29:1:200	2-3	..X.	
D29:1:320	2-3	..X.	
D29:2:016	2-3	..X.	
D29:2:017	2-3	..X.	
D29:2:018	2-3	..X.	
D29:2:200	2-3	..X.	
D29:2:220	2-3	..X.	
D29:3:200	2-3	..X.	

Return More View Logical Ports

Return

Use cursor keys to choose item. Press <ENTER> to confirm choice.
Press <CTRL><N> to return to Main Menu.

Figure 4-4. Master Route Descriptor Table Panel

The following list describes information available on the Master Route Descriptor Table:

Route Descriptor

Route descriptors represent remote bridge IDs and associated segment numbers that are reachable via the designated Local Port. Only the "next hop" portion of the route descriptor is required for Source Route Switching.

Local Port

The port that is in the forwarding path for a specifically routed frame to reach the bridge designated in the route descriptor, or unknown if this route descriptor has only been received as a destination.

Ports All ports whose tables include this route descriptor.

Notes:

1. Port columns for which no port exists contain blanks.
2. Ports that exist but do not have the indicated route descriptor in their table contain a period (.).
3. Ports that exist and have the indicated route descriptor in their table contain an X.

Viewing Switch Statistics

From the Status/Statistics Menu, select **Switch Statistics...** Use the Switch Statistics panel shown in Figure 4-5 to view information about stations connected to the 8270.

Switch Statistics	
System Up Time	2 Hr, 1 Min, 47 Sec
Board Temperature	Normal
Currently Active Addresses	58
Largest Number of Addresses	58
Maximum Number of Addresses	10000
Frames Transmitted	543
Frames Received	969
Error Frames Received	18
Frames Lost	0
Pending Send Requests	0
Frame Transmit Errors	2
Maximum Address Chain	3
Address Table Full	0

Return Reset_Statistics

Return to previous menu
Press <ENTER> to exit menu.
Press <CTRL><N> to return to Main Menu.

Figure 4-5. Switch Statistics Panel

The following list defines information available on the Switch Statistics panel:

System Up Time

Displays the length of time since the last reset or power cycle.

Board Temperature

Indicates the board temperature as either Normal or Abnormal.

Currently Active Addresses

Displays the number of entries in the address table, representing the number of currently active stations, or nodes, on all ports of the 8270.

Largest Number of Addresses

Displays the largest number of addresses in the address table at any one time since the last reset or power cycle.

Maximum Number of Addresses

Displays the maximum number of stations that the 8270 can support simultaneously.

Frames Transmitted

Displays the number of frames transmitted from the 8270 processor to its ports.

Frames Received

Displays the number of frames received by the 8270 processor.

Error Frames Received

Displays the number of frames not successfully received.

Frames Lost

Displays the number of frames lost because software processing queues were full.

Pending Send Requests

Displays the number of frames in the Send Queue.

Frame Transmit Errors

Displays the number of frames not transmitted because of transmit errors.

Maximum Address Chain

Displays the maximum number of addresses having the same index.

Address Table Full

Displays the number of times the address table has been full.

Viewing the Message Log Information

From Status/Statistics Menu, select **Message Log Information....** Use the Message Log Information panel to view the message log.

```
Message Log Information

Log  Type  Message Content
-----
 1    W    Fri. September 8, 1995 14:18:12
      8270 failed to find bootp server on one or more
      domains (still trying...)
 0    I    Tue. April 14, 1998 14:05:27
      IBM 8270 Nways System has been started
      Main Image Version: 3.61

Return  More  Clear_Logs  Search

Return to previous menu
Use cursor keys to choose item. Press <ENTER> to confirm choice.
Press <CTRL><N> to return to Main Menu.
```

Figure 4-6. Message Log Information Panel

The data on this panel is used by technical experts in diagnosing and solving complex problems. An explanation of all the messages that can appear in this log is beyond the scope of this manual.

The existence of a message does not mean there is a problem. Rather, this panel displays information about your switch. For information only, when diagnosing a problem with technical experts.

Some messages reference an internal port number. See Appendix D, "Internal Port Mapping" on page D-1 to correlate internal port numbers to external port names.

Viewing the Domain Address Table

From the Status/Statistics Menu, select **Domain Address Table...** Use the Domain Address Table to view the station addresses of all ports known to the selected domain.

Domain Address Table for Domain: default						
		Ports - Filtered Ports High-Lighted				
MAC Address	Local Port	Slot2	Slot3	Slot4	Slot5	Slot7
0004AC 281320	Swch Base	XXXX	XX..	XXXX	XXXX	XXXX
0004AC 281340	default	XXXX	XX..	XXXX	XXXX	XXXX
0004AC 3438DE	2-1	X...
002000 0344B4	2-1	X...
080020 790F48	2-1	X...	XXXX
08005A 0C025D	2-1	X...	XXXX
08005A 226395	2-1	X...
08005A 22FCF5	2-1	X...
08005A A40179	2-1	X...
08005A A401FF	2-1	X...
08005A D40160	2-1	X...

Return More Search Change_Displayed_Domain... View_Logical_Ports

Return

Use cursor keys to choose item. Press <ENTER> to confirm choice.
Press <CTRL><N> to return to Main Menu.

Figure 4-7. Domain Address Table Panel

The following list describes the information shown on the Domain Address Table:

MAC Address

Displays the MAC address of a node.

Local Port

The port where this MAC address was received as a source address, or unknown if it has only been received as a destination address. This field will also identify addresses internal to the switch, as well as permanent multicast addresses.

Ports Displays the ports whose address tables include this MAC address.

Notes:

1. Port columns for which no port exists contain blanks.
2. Ports that exist but do not have the indicated MAC address in their address table contain a period (.).
3. Ports that exist and have the indicated MAC address in their address table contain an X.

Viewing the Domain Route Descriptor Table

From the Status/Statistics Menu, select **Domain Route Descriptor Table...** Use the Domain Route Descriptor Table to view the route descriptors of all ports known to the selected domain. Entries are sorted by route descriptor, treating it as one large number.

Domain Route Descriptor Table for Domain: default						
Route Descriptor	Local Port	Ports:				
		Slot2 1234	Slot3 1234	Slot4 1234	Slot5 1234	Slot6 1234
D29:1:016	2-4	...X
D29:1:017	2-4	...X
D29:1:018	2-4	...X
D29:1:170	2-4	...X
D29:1:1ED	2-4	...X
D29:1:456	2-4	...X
D29:1:9DB	2-4	...X
D29:1:9F0	2-4	...X
D29:1:D2A	2-4	...X
D29:2:016	2-4	...X
D29:2:017	2-4	...X

Return More Change_Displayed_Domain... View_Logical_Ports

Return
Use cursor keys to choose item. Press <ENTER> to confirm choice.
Press <CTRL><N> to return to Main Menu.

Figure 4-8. Domain Route Descriptor Table Panel

The following list describes information available on the Domain Route Descriptor Table:

Route Descriptor

Displays the route descriptor associated with a port. Route descriptors represent paths through external source-route bridges.

Local Port

The port that is in the forwarding path for a specifically routed frame to reach the bridge designated in the route descriptor, or unknown if this route descriptor has only been received as a destination.

Ports All ports whose tables include this route descriptor.

Notes:

1. Port columns for which no port exists contain blanks.
2. Ports that exist but do not have the indicated route descriptor in their table contain a period (.).
3. Ports that exist and have the indicated route descriptor in their table contain an X.

Viewing Domain Statistics

From the Status/Statistics Menu, select **Domain Statistics...** Use the Domain Statistics panel to view the current number of addresses and the largest number of addresses in the master address table for the selected domain.

```
Domain Statistics for Domain: default
Change_Displayed_Domain...
Currently Active Addresses           143
Largest Number of Addresses         1434
Maximum Number of Addresses         10000

Return

Return to previous menu
Press <ENTER> to exit menu.
Press <CTRL><N> to return to Main Menu.
```

Figure 4-9. Domain Statistics Panel

The following list describes the information available on the Domain Statistics panel.

Currently Active Addresses

Displays the number of addresses currently in the master address table that are recognized by ports belonging to this domain.

Largest Number of Addresses

Displays the largest number of addresses in the master address table since the last reset or power cycle that are recognized by ports belonging to this domain.

Maximum Number of Addresses

Displays the maximum number of addresses allowed on the domain.

Viewing Transparent Bridge Spanning Tree Statistics

From the Status/Statistics Menu, select **Transparent Bridge Spanning Tree....**

This panel provides a summary of all Spanning Tree information for each port. You cannot change information using this panel.

Note: When the 8270 is configured with TokenPipes, Spanning Tree packets use the primary (lowest-numbered) port of the TokenPipe.

```
Transparent Bridge Spanning Tree for domain: default

Hello Time: 20, Max Message Age: 20, Forward Delay: 15
Root: 30000.FFFF0000001F, Root Port: This Bridge is Root

Port  Port Port  Desig  Designated      Desig  #Topo  Time Since
ID    Cost STS   Cost  Switch/Bridge  ID    PortID  Chgs   Last Change
-----
128.01  0 FWD    0 30000.FFFF0000001F 128.01  1      0:27:45

Return More Change_Displayed_Domain...

Return
Use cursor keys to select action. Press <ENTER> to confirm choice.
Press <CTRL><N> to return to Main Menu.
```

Figure 4-10. Transparent Bridge Spanning Tree Information Panel

The following list defines each of the parameters displayed on the Transparent Bridge Spanning Tree Information panel:

Hello Time

Displays the Hello Time, in seconds, that is advertised by the root and used by all devices and switches in the active topology of the Spanning Tree network.

Max Message Age

Displays the Maximum Message Age, in seconds, that is advertised by the root and used by all devices and switches in the Spanning Tree network.

Forward Delay

Displays the Forward Delay time, in seconds, that is advertised by the root and used by all devices and switches in the Spanning Tree network.

Root Displays the priority and MAC address of the device in the Spanning Tree that this switch has accepted as the root device.

Root Port

Displays the number of the port on this switch that is closest to the root. This switch communicates with the root through this port. If there is no root port, this switch has been accepted as the root of the Spanning Tree network.

Port ID Displays the port ID that is used to determine the role of the port in the Spanning Tree. The port ID is expressed in the form:

port priority.port number

Port Cost

Displays the Port Path Cost for each port on the switch. The Port Path Cost helps determine the role of the port in the Spanning Tree.

Port STS (status)

Displays the current status of this port within the spanning tree:

- DSB** Disabled
- BLK** Blocked
- LSN** Listening
- LRN** Learning
- FWD** Forwarding

The rules that define the state of the port are as follows:

- A port on a network segment with no other switch or bridge is always forwarding.
- If two ports of the 8270 are connected to the same network segment and there is no other bridge or switch, the port with the smaller ID is forwarded and the other is blocked.
- When the switch is booted, all ports are blocked initially, and then some of them change to a different state: listening, learning, or forwarding, in that order. To see the change in states you must repeatedly exit from this menu, and then select it again. All ports that are going to change states from blocking to forwarding will have done so after two to three times the value of:

Switch Maximum Message Age + (2 × Switch Forward Delay)

Designated Cost

Displays the cost for a packet to travel from this port to the root in the current Spanning Tree configuration. The slower the media, the higher the cost.

Designated Switch/Bridge ID

Displays the Priority and Station address of the device through which this port has determined it must communicate with the root of the Spanning Tree.

Designated Port ID

Displays the port on the designated bridge through which this switch communicates with the root of the Spanning Tree. This information is useful if the 8270 is the designated bridge on one or more network segments.

The Designated Port ID is displayed as an internal port number. If the designated bridge is an IBM LAN Switch, the internal port number can be correlated to an external port name using the table in Appendix D, "Internal Port Mapping" on page D-1.

Topo Changes

Displays the number of topology changes, that is, the number of times the port has entered the forwarding state plus the number of times the port has made the transition from forwarding to blocking. The counter is reset when the 8270 is reset or the Spanning Tree is turned on.

Time Since Last Change

Displays the time since the last time that the port entered the forwarding state or made the transition from forwarding to blocking.

Viewing Port Status

From the Status/Statistics Menu, select **Port Status....** to view the status of the ports.

Port Status							
Port	Switching Mode	State	Link	Speed	Mode	Duplex	Error Rate
13	-----	Enabled	Down	--	----	----	----
14	Store & Fwd	Enabled	Up	4	Adpt	Half	0%
15	-----	Enabled	Down	--	----	----	----
16	Cut-Through	Enabled	Up	16	Adpt	Half	0%
1-1	-----	Enabled	Down	--	----	----	----
1-2	-----	Enabled	Down	--	----	----	----

Return More

Display the next page of the port status table
Use cursor keys to choose item. Press <ENTER> to confirm choice.
Press <CTRL><N> to return to Main Menu.
Port Status

Figure 4-11. Port Status Panel

The following list defines parameters displayed on this panel:

Switching Mode

Displays one of the two possible switching modes, Cut-Through and Store-and-Forward.

- **Cut-Through:** The highest-speed switching mode (16 Mbps).
- **Store-and-Forward:** The mode that provides improved error isolation at the expense of some speed for 16-Mbps ports.

State Displays the operational state of the ports. Possible values are Enabled, Disabled, and Cfg Loss.

Link Indicates whether the port is up (open) or down (closed).

Speed Displays the speed of the port in Mbps.

Mode Displays either Port mode or Adapter mode.

Port Mode

In Port mode, only a dedicated connection to a station is supported. The Tx/Rx pinouts are the same as a concentrator's.

Adapter Mode

In adapter mode, the port operates like a station. The connection can be either dedicated or shared. The Tx/Rx pinouts are the same as an adapter's.

Duplex Displays the current configuration of Duplex mode for this port.

Error Rate

The percentage of frames received in error during the last sampling period. See "Switching Mode Threshold (Token-Ring Ports only)" on page 3-49 for further description.

Viewing TokenPipe Status

From the Status/Statistics Menu, select **TokenPipe Status....** to view the status of TokenPipes.

TokenPipe Status		
TokenPipe	State	Ports
1	Up	2-1 2-2
2	N/A	Not Defined
3	N/A	Not Defined
4	N/A	Not Defined

Return

Return to previous menu
Use cursor keys to select action. Press <ENTER> to confirm choice.
Press <CTRL><N> to return to Main Menu.

Figure 4-12. TokenPipe Status Panel

The following list describes information available on the TokenPipe status panel:

State Indicates that a TokenPipe is either

- Up (enabled and connected)
- Down (enabled and not connected)
- N/A (not enabled).

Ports Indicates ports included in the TokenPipe.

Note: Create TokenPipe port connections between 8270s in consecutive, numeric order from lowest-to-highest numbered port. The lowest-numbered port becomes the primary port and all broadcast frames flow through this port as TokenPipe connections are created and then assigned to the other TokenPipe ports. If any strand in the TokenPipe fails, the entire TokenPipe becomes inoperative.

Viewing the Port N Address Table

From the Status/Statistics Menu, select **Port N Address Table...** You are prompted to specify a port number, after which the Address Table for that port is displayed. Use the Port N Address Table to view the MAC addresses of nodes connected to a specific port, and to view the Spanning Tree status of this port. This table includes MAC addresses from which this port has received packets or to which it has sent packets. It can contain up to 1790 entries.

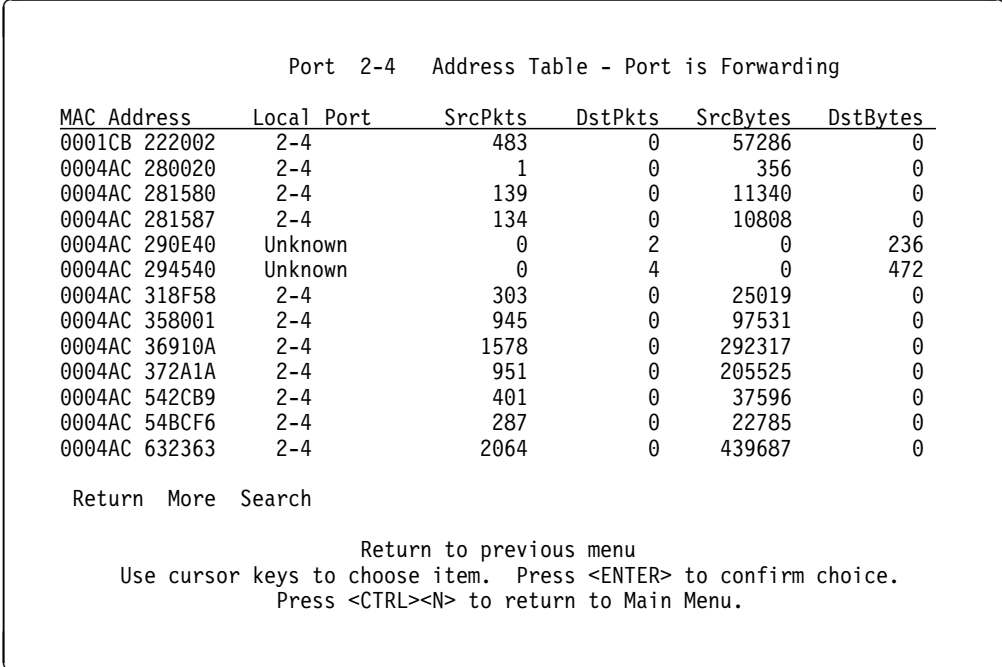

Port 2-4 Address Table - Port is Forwarding

MAC Address	Local Port	SrcPkts	DstPkts	SrcBytes	DstBytes
0001CB 222002	2-4	483	0	57286	0
0004AC 280020	2-4	1	0	356	0
0004AC 281580	2-4	139	0	11340	0
0004AC 281587	2-4	134	0	10808	0
0004AC 290E40	Unknown	0	2	0	236
0004AC 294540	Unknown	0	4	0	472
0004AC 318F58	2-4	303	0	25019	0
0004AC 358001	2-4	945	0	97531	0
0004AC 36910A	2-4	1578	0	292317	0
0004AC 372A1A	2-4	951	0	205525	0
0004AC 542CB9	2-4	401	0	37596	0
0004AC 54BCF6	2-4	287	0	22785	0
0004AC 632363	2-4	2064	0	439687	0

Return More Search

Return to previous menu
Use cursor keys to choose item. Press <ENTER> to confirm choice.
Press <CTRL><N> to return to Main Menu.

Figure 4-13. Port N Address Table Panel

The following list describes information available on the Port N Address Table:

Address

Displays the MAC address of a node. Ports that belong to a TokenPipe are designated as primary or secondary. The lowest switch port number participating in the TokenPipe is the primary port; this port is used for all broadcast traffic.

Local Port

Displays the port to which the node is attached.

Viewing the Port N Route Descriptor Table

From the Status/Statistics Menu, select **Port N Route Descriptor Table...** You are prompted to specify a port number, after which the Route Descriptor Table for that port is displayed. Use the Port N Route Descriptor Table to view the route descriptors of nodes connected to a specific port. This table includes route descriptors from which this port has received packets or to which it has sent packets. These descriptors are contained within the 1790 entries allowed for learned MAC addresses on a port. Entries are sorted by route descriptor, treating it as one large number.

Port 2-4 Route Descriptor Table

<u>Route Descriptor</u>	<u>Local Port</u>	<u>SrcPkts</u>	<u>DstPkts</u>	<u>SrcBytes</u>	<u>DstBytes</u>
222:B:444	2-4	0	0	0	0

Return More Search

Return to Previous Menu
Use cursor keys to choose item. Press <ENTER> to confirm choice.
Press <CTRL><N> to return to Main Menu.

Figure 4-14. Port N Route Descriptor Table Panel

The following list defines information available on the Port N Route Descriptor Table:

Route Descriptor

Displays the route descriptor associated with a port. Route descriptors represent paths through external source-route bridges.

Local Port

The port that is connected to the bridge designated in the route descriptor.

Viewing Port N Statistics

From the Status/Statistics Menu, select **Port N Statistics...** You are prompted to specify a port number, after which the Statistics panel for that port is displayed. Use the Port N Statistics panel to view detailed information about a particular port.

```
Port 2-4 Statistics - Port is Forwarding

Frames Received                2100676
Octets Received                922292355
Frames Transmitted             1470
Octets Transmitted             91976
Multicast/Broadcast Frames Received 2485
Frames Local to Port (not forwarded) 838457
Frames Switched by Hardware    23348
Frames Delivered to Processor  1238872
All Forwarded Frames          1262220
Number of Learned Stations     302
Currently Active Addresses     105
Local Address Entries          87
Remote Address Entries         18
Largest Number of Addresses    109
Address Table Overflows        0
Time Since Last Reset          0 Hr, 40 Min, 21 Sec

Return More Reset_Statistics

Return to previous menu
Use cursor keys to choose item. Press <ENTER> to confirm choice.
Press <CTRL><N> to return to Main Menu.
```

Figure 4-15. Port N Statistics Panel (1 of 2)

The following list describes information available from the Port N Statistics panel:

Frames Received

Displays the number of frames received by the port.

Octets Received

Displays the bytes received.

Frames Transmitted

Displays the number of frames transmitted by the port.

Octets Transmitted

Displays the bytes transmitted.

Multicast/Broadcast Frames Received

Displays the number of frames received that have the multicast bit set. This count is not based on RIF information, and does not include explorer frames.

Frames Local to Port (not forwarded)

Displays the number of frames that are confined to this segment and are not forwarded by the switch.

Frames Switched by Hardware

Displays the number of frames received on this port and forwarded by the 8270 hardware to another port without being sent to the processor.

Frames Delivered to Processor

Displays the number of frames received on this port and forwarded to the processor for any reason.

All Forwarded Frames

Displays the number of frames received on this port and forwarded by the 8270 hardware or software.

Number of Learned Stations

Displays the number of frames sent to the processor for address learning.

Currently Active Addresses

Displays the sum of local and remote addresses.

Local Address Entries

Displays the number of addresses on this port that belong to the local segment.

Remote Address Entries

Displays the number of addresses on this port that belong to another segment.

Largest Number of Addresses

Displays the largest number of addresses active since the last reset of the 8270.

Address Table Overflows

Displays the number of times the address table has reached maximum entries.

Time Since Last Reset

Displays the hours, minutes, and seconds since the port traffic counters were last reset.

```

Port 2-4 Statistics - Port is Forwarding
Unicast Frames Received          1131767
Non-Unicast Frames Received      1043609
Hi Port Bytes Transmitted        75780
Low Port Bytes Transmitted       20056
Hi Port Unicast Frames Xmt       0
Low Port Unicast Frames Xmt      259
Hi Port Non-Unicast Frames Xmt   1263
Low Port Non-Unicast Frames Xmt  0
Receive Buffer Queue Full        0
Receive Internal Packet Errors   0
Receive Frames Too Long         0
Hi Port Internal Packet Errors   0
Low Port Internal Packet Errors  0
Hi Port Packets in Queues        0
Low Port Packets in Queues       0
Transmit Buffer Queue Full       0
Port DATA Bus Timeout Errors   0

Return   More   Reset_Statistics

                Display more port statistics
                Use cursor keys to choose item. Press <ENTER> to confirm choice.
                Press <CTRL><N> to return to Main Menu.

```

Figure 4-16. Port N Statistics Panel (2 of 2)

The statistics shown in Figure 4-16 provide additional granularity for analyzing traffic and switch performance statistics. Some error events occur periodically and are captured for possible fault analysis. The following list defines statistics available on the Figure 4-16:

Unicast Frames Received

The number of frames received by this port that are designated for a single destination address.

Non-Unicast Frames Received

The number of frames that were forwarded to more than one port. This includes unknown destinations, explorer frames, and frames with the multicast bit set.

Hi Port Bytes Transmitted

The number of bytes transmitted from the high-priority transmit queue.

Low Port Bytes Transmitted

The number of bytes transmitted from the low-priority transmit queue.

Hi Port Unicast Frames Xmt

The number of unicast frames transmitted from the high-priority transmit queue.

Low Port Unicast Frames Xmt

The number of unicast frames transmitted from the low-priority transmit queue.

Hi Port Non-Unicast Frames Xmt

The number of general broadcast or multicast frames transmitted from the high-priority transmit queue.

Low Port Non-Unicast Frames Xmt

The number of general broadcast or multicast frames transmitted from the low-priority transmit queue.

Receive Buffer Queue Full

The number of instances in which a packet arrived on the input link and there were no available receive buffers.

Receive Internal Packet Errors

The number of packets received with an error (CRC, frame fragment, exceeded maximum frame length, etc.) that resulted in abnormal termination of the receive process.

Receive Frames Too Long

The number of frames received that exceed the maximum frame length limit of 4540 bytes.

Hi Port Internal Packet Errors

The number of transmits from the high-priority transmit queue in which an abnormal frame termination occurred. These error counters might be an indication of link errors due to noise or other interference that result in unsuccessful packet transmission by the switch port.

Low Port Internal Packet Errors

The number of transmits from the low-priority transmit queue in which an abnormal frame termination occurred. These error counters might be an indication of link errors due to noise or other interference that result in unsuccessful packet transmission by the switch port.

Hi Port Packets in Queues

The current number of packets in the high-priority transmit queue awaiting transmission.

Low Port Packets in Queues

The current number of packets in the low-priority transmit queue awaiting transmission.

Transmit Buffer Queue Full

The number of packets lost due to the inability of the transmit queue to accept a packet from another port.

Port DATA Bus Timeout Errors

The number of receive packets discarded due to failure of the target port to accept the packet.

Viewing Port N Filters

From the Status/Statistics Menu, select **Port N Filters....** You are prompted to specify a port number after which the filters panel for that port is displayed. Use the Port N Filters panel to display the defined filters and security mode for the specified port.

```
Port 1-1 Filters - Security Mode is Normal

Index  MAC Address  Description
-----
1      10005A 4315CF  This address is blocked

Return  More

Return to previous menu
Use cursor keys to choose item. Press <ENTER> to confirm choice.
Press <CTRL><N> to return to Main Menu.
```

Figure 4-17. Port N Filters Panel

Viewing Source-Route Bridge Spanning Tree Status

From the Status/Statistics Menu, select **Source-Route Bridge Spanning Tree Status...** This panel shows the current status of the source-route Spanning Tree.

Source-Route Bridge (SRB) Spanning Tree Status						
Bridge Number	1	Mode	Automatic			
SRB Hello Time	20	Root Device	xxxxxx.xxxxxxxxxxxxxx			
SRB Max Message Age	20	Root Segment	xxx			
SRB Forward Delay	15					
Designated Path to the Root						
Segment ID	Segment Cost	Segment Status	Segment ID	Cost	Bridge ID	
001.1	62	FWD	xxx.x	xx	xxxxxx.xxxxxxxxxxxxxx	
002.1	62	FWD	xxx.x	xx	xxxxxx.xxxxxxxxxxxxxx	
222.1	62	FWD	xxx.x	xx	xxxxxx.xxxxxxxxxxxxxx	
Return	More					
Return to previous menu						
Use cursor keys to choose an item. Press <ENTER> to confirm your choice.						
Press <CTRL><N> to return to Main Menu.						

Figure 4-18. Source-Route Bridge Spanning Tree Status Panel

Attention: When Spanning Tree mode is Manual, the only fields displayed are:

- Bridge Number
- Mode (shown as Manual)
- Segment ID
- Segment Status

All of the other fields appear only when the Mode is Automatic.

Bridge Number

The number of the bridge located on this switch.

SRB Hello Time

The Hello Time, in seconds, that is advertised by the root and used by all devices and switches in the active topology of the Source-Route Bridge Spanning Tree network.

SRB Maximum Message Age

The Maximum Message Age, in seconds, that is advertised by the root and used by all devices and switches in the Source-Route Bridge Spanning Tree network.

SRB Forward Delay

The Forward Delay time, in seconds, that is advertised by the root and used by all devices and switches in the Source-Route Bridge Spanning Tree network.

Mode Automatic indicates that the ports are automatically set to Forwarding or Blocked if there are parallel paths. Manual indicates that the user must configure these settings manually.

Root Device

Displays the priority and MAC address of the device in the Source-Route Bridge Spanning Tree that this switch has accepted as the root device.

Root Segment

Displays the segment number of the segment on this switch that is closest to the root. The switch communicates with the root through this segment.

Segment ID

Segment ID of a domain which is participating in the Source-Route Bridge. The Segment ID is expressed in the form of segment number.bridge number.

Segment Cost

Displays the Segment Path Cost for each segment which is a member of the Source-Route Bridge. The Segment Path Cost helps determine the role of the segment in the Source-Route Bridge Spanning Tree.

Segment Status

Displays the current status of this segment within the Source-Route Bridge Spanning Tree as follows:

- BLK—Blocked
- LSN—Listening
- FWD—Forwarding

Designated Path to the Root - Segment ID

Displays the segment ID to the designated bridge through which this switch communicates with the root of the Source-Route Bridge Spanning Tree. The Segment ID is expressed in the form:

segment number.bridge number

Designated Path to the Root - Cost

Displays the cost for a packet to travel from this segment to the root of the current Source-Route Internal Bridge spanning tree configuration.

Designated Path to the Root - Bridge ID

Displays the priority and station address of the device through which this segment has determined it must communicate with the root of the Source-Route Bridge Spanning Tree.

LAN Segment Selection List for Viewing SRB Statistics

From the Status/Statistics Menu, select **LAN Segment N SRB Statistics....** This panel allows you to select the domain for which you want to view source-route bridge statistics.

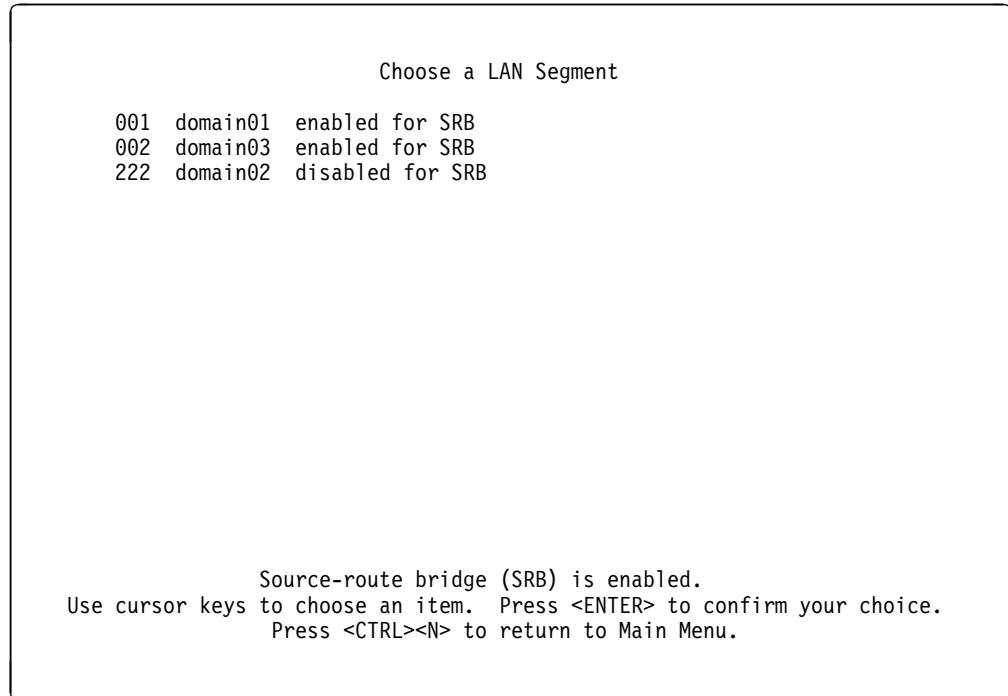

Figure 4-19. Source-Route Bridge LAN Segment Selection Panel

Selecting a segment and pressing **Enter** takes you to the Source-Route Bridge (SRB) Statistics panel.

Viewing Source-Route Bridge Statistics

This panel allows you to reset the source-route bridge statistics for the domain selected in the Choose a LAN Segment and Domain Name panel.

```
Segment 001 - domain01 - Source-Route Bridging (SRB) Statistics
Time Since Last Reset      0 Hr.  0 Min.  0 Sec.

Traffic Counters                Frames In      Frames Out
Specifically routed frames.....          0             0
All-routes explorer (ARE) frames.....    0             0
Spanning Tree Explorer (STE) frames..    0             0

Hop Count (RIF Length) Discards  Recv Hop Count  Xmit Hop Count
ARE hop count exceeded.....              0             0
STE hop count exceeded.....              0             0

Other Discarded Frame Counters
Segment mismatch.....                    0
Duplicate segment.....                   0
Duplicate LAN ID or Tree Error.....       0
Input queue overflow.....                 0
Output queue overflow.....                0

Return  Change_Displayed_Segment  Reset Statistics

Return to previous menu
Use cursor keys to choose an item. Press <ENTER> to confirm your choice.
Press <CTRL><N> to return to Main Menu.
```

Figure 4-20. Source-Route Bridge Statistics Panel

Specifically routed frames - Frames In

The number of specifically routed frames which have entered this domain from the network and then traversed the Source-Route Bridge.

Specifically routed frames - Frames Out

The number of specifically routed frames which have traversed the Source-Route Bridge and then been put on the network from this domain.

All-routes explorer (ARE) frames - Frames In

The number of All-routes explorer frames which have entered this domain from the network and then traversed the Source-Route Bridge.

All-routes explorer (ARE) frames - Frames Out

The number of All-routes explorer frames which have traversed the Source-Route Bridge and then been put on the network from this domain.

Spanning Tree explorer (STE) frames - Frames In

The number of Spanning Tree explorer frames which have entered this domain from the network and then traversed the Source-Route Bridge.

Spanning Tree explorer (STE) frames - Frames Out

The number of Spanning Tree explorer frames which traversed the Source-Route Bridge and then been put on the network from this domain.

ARE hop count exceeded - Recv Hop Count

The number of All-routes explorer frames which have been discarded because the receive hop count was exceeded.

ARE hop count exceeded - Xmit Hop Count

The number of All-routes explorer frames which have been discarded because the transmit hop count was exceeded.

STE hop count exceeded - Recv Hop Count

The number of Spanning Tree explorer frames which have been discarded because the receive hop count was exceeded.

STE hop count exceeded - Xmit Hop Count

The number of Spanning Tree explorer frames which have been discarded because the transmit hop count was exceeded.

Segment Mismatch

The number of explorer frames which have been discarded because the routing descriptor field contained an invalid segment value for this domain.

Duplicate segment

The number of frames which have been discarded because the routing descriptor field contained a duplicate segment identifier.

Duplicate LAN ID or Tree Error

The number of Spanning Tree explorer frames which have been discarded because they appeared at the bridge more than once.

Input queue overflow

The number of explorer frames which have been discarded because there were insufficient input buffers to forward them across the Source-Route Bridge.

Output queue overflow

The number of explorer frames which have been discarded because there were insufficient output buffers to forward them across the Source-Route Bridge.

Change Displayed Segment

Scroll to the next LAN segment's statistics.

Reset Statistics

Set the statistics to 0.

Chapter 5. Resetting the 8270

Attention: Resetting the 8270 will interrupt all network traffic through the 8270.

Two kinds of reset operations can be performed by the 8270. You can reset the 8270 and run internal diagnostics (cold boot) or you can reset the 8270 and not run internal diagnostics (warm boot).

Note: LED indications that show the result of diagnostic tests are not given in real time. You must reset the switch with diagnostics (cold boot) in order to determine whether the LEDs are alerting you to a problem with the 8270.

Resetting with Diagnostics (Cold Boot)

There are two ways to cold-boot the 8270. You can initiate a cold boot using the Reset Menu (see "Reset/Diagnostics" on page 5-2) or you can temporarily interrupt ac power input.

Since there is no power switch on the 8270, ac power is interrupted by unplugging the line cord at the ac outlet.

Resetting without Diagnostics (Warm Boot)

There are two ways to warm-boot the 8270. You can initiate a warm boot using the Reset/Diagnostics menu (see "Reset/Diagnostics" on page 5-2) or you can press the Reset button on the Token-Ring Processor Card.

Reset/Diagnostics

From the Main Menu, select **Reset/Diagnostics...** Use the Reset/Diagnostics panel to reset the 8270 and run diagnostics.

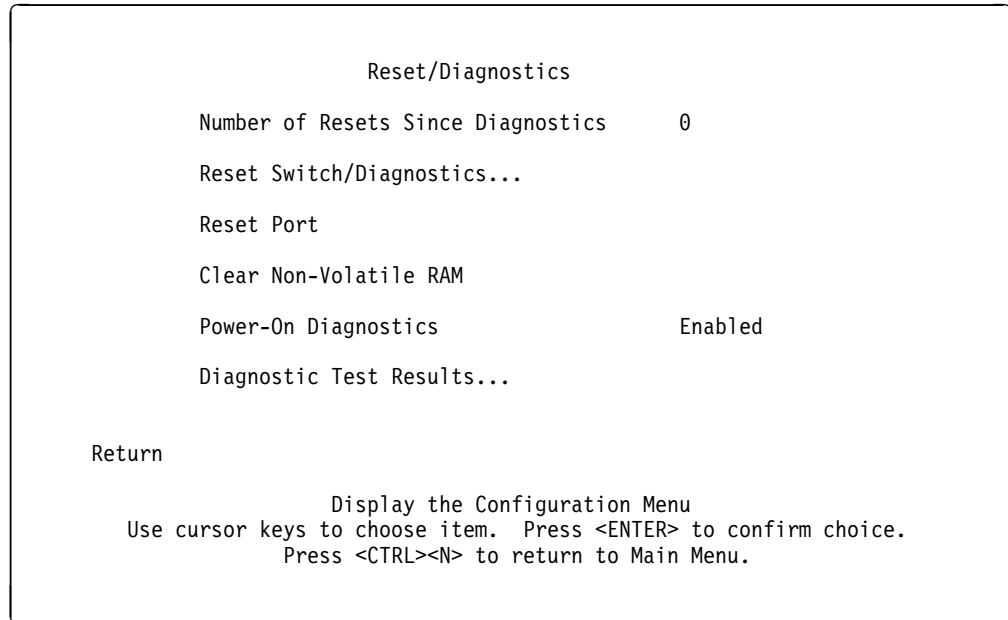

Figure 5-1. Reset/Diagnostics Panel

Number of Resets Since Diagnostics

Displays the number of times the unit has been reset since the unit was powered on or ran power-on diagnostics. This number is not reset to 0 when you reset the address table for the port.

Reset Port

Clears all table entries for a selected port, sets all port traffic counters to 0, and sets Time since Last Reset to 0.

Clear Non-Volatile RAM

Deletes all user-configured parameters, such as IP address and baud rate information, and resets the 8270.

Note: Clearing NVRAM erases all configuration parameters. If you are using the TokenPipe feature, be sure to disconnect the affected ports or disable them on the Port Configuration panel and reset the switch **before** clearing NVRAM. If you are using the Spanning Tree option, it is turned off and port costs and priorities are lost, which can result in loops. Use the Spanning Tree panels to reestablish port costs and priorities. If you are using an SNMP manager, reconfigure all IP and SNMP parameters.

Power-On Diagnostics

Enables or disables the running of power-on diagnostics when the 8270 is powered on. The default is Enabled. It is recommended that you do not change this option. (However, disabling the power-on diagnostics could greatly reduce recovery time from unexpected power outages.)

Diagnostic Test Results

Show the results of the most recent running of power-on diagnostics. See Figure 5-2 on page 5-3.

Diagnostic Test Results	
<u>Diagnostic Test</u>	<u>Result</u>
Number of Test Loops	1
CPU Subsystem	Passed
Port Memory	Passed
Port Registers	Passed
T/R Port Loopback Test	Passed
T/R POE Test	Passed
T/R Port Advanced Memory Test	Skipped
T/R Cross Port Test	Passed
T/R Port Broadcast Test	Passed
CPU Broadcast Test	Passed

Return

Return to previous menu
Use cursor keys to select action. Press <ENTER> to confirm choice.
Press <CTRL><N> to return to Main Menu.

Figure 5-2. Diagnostic Test Results Panel

Reset Switch/Diagnostics

From the Main Menu, select **Reset Switch/Diagnostics...** There are three options:

- **Reset Switch with Diagnostics**

Resets the 8270 hardware, runs diagnostic tests, clears all counters including address tables, and starts the 8270. This does not clear any user-configured parameters. When the 8270 restarts, parameters from NVRAM are used to initiate the operational parameters.
- **Reset Switch without Diagnostics**

Resets the switch hardware, clears all counters including address tables, and starts the 8270. This does not clear any user-configured parameters. When the 8270 restarts, parameters from NVRAM are used to initiate operational parameters.
- **Reset Switch with Advanced Memory Test**

Performs a Reset with Diagnostics and extensive memory tests. This test can take over an hour to run.

If the 8270 is connected to a terminal via the EIA 232 port, a series of diagnostic messages should appear after you reset the 8270 with diagnostics. An example of these messages is shown in Figure 5-3 on page 5-5. An abbreviated version of this set of messages will appear if you reset the 8270 without diagnostics.

```

- Initiating bootstrapping sequence v5.0...
- Boot image integrity check...Passed.
- Control transferred to boot process.

Boot Test
- Relocating main image to DRAM.....Done.
- Main image integrity check...succeeded.
- Control transferred to main process.

Tue. April 14, 1998 15:50:20
IBM 8270 Nways System has been started
Main Image Version: x.xx
4 Megabytes System memory
2 Megabytes Network memory
- Initialization started
- File system initialized
- System fans OK
- Power supply 2 not present
- System power supply voltages OK
- System temperature is within safe operating levels
- No existing diagnostic information, forcing diagnostic mode
- Coldboot initialization started
- Checking file system integrity
- LAN ports detected:
  - Token Ring Ports: 2-1 2-2 2-3 2-4
                      3-1 3-2 3-3 3-4 4-1 4-2 4-3 4-4
                      5-1 5-2 5-3 5-4 6-1 6-2 6-3 6-4

  - Slot 1: Empty
  - Slot 2: 4 Port TR Expansion Card
  - Slot 3: 4 Port TR Expansion Card
  - Slot 4: 4 Port TR Expansion Card
  - Slot 5: 4 Port TR Expansion Card
  - Slot 6: 4 Port TR Expansion Card
  - Slot 7: Empty
  - Slot 8: Empty
- CPU Network memory test...Passed
- Initializing Ports: 2-1 2-2 2-3 2-4
                    3-1 3-2 3-3 3-4 4-1 4-2 4-3 4-4
                    5-1 5-2 5-3 5-4 6-1 6-2 6-3 6-4
- Initializing system address table
- Starting Power Up Diagnostic
  - Downloading Ports: 2-1 2-2 2-3 2-4
                     3-1 3-2 3-3 3-4 4-1 4-2 4-3 4-4
                     5-1 5-2 5-3 5-4 6-1 6-2 6-3 6-4
  - UART loopback test on diagnostic port...Passed
  - UART loopback test on console port...Passed
  - Real Time Clock memory test...Passed
  - Real Time Clock test...Passed
  - CPU Port loopback test.....Passed
  - Token Ring Port Loopback Test.....Passed
  - Token Ring Port Cross Port Loopback Test...Passed
  - CPU Port Broadcast Test...Passed
- Completing Power Up Diagnostic
- Activating Ports: 2-1 2-2 2-3 2-4
                  3-1 3-2 3-3 3-4 4-1 4-2 4-3 4-4
                  5-1 5-2 5-3 5-4 6-1 6-2 6-3 6-4

- Activating IP
- IBM 8270 Nways Token-Ring LAN Switch Model 800 initiating bootp
  requests on one or more domains
- System initialization complete

```

Figure 5-3. Messages during Diagnostics

Chapter 6. Updating Software

This chapter contains customer procedures for downloading software upgrades to the 8270 flash EEPROM. Due to periodic updates to this code, customers should check for more recent code (a higher number) than that which is currently installed on your switch.

Note: The 8270 is not operational during a reset. Before starting this procedure, make sure that the network will not be affected.

The Interface Description on the Switch Information panel shows the hardware and software version of the 8270. The port microcode level applies to code related to physical port function.

Download the Diskette Image from the Internet

The following files for the 8270 code upgrade can be downloaded from <http://www.networking.ibm.com/support> by downloading the self-extracting file, 8270xxxx.exe. The file contains:

	File name	Contents
a.	TRS_Bxxx.GZ	Main image
b.	TRS_Bxxx.BT	Boot image
c.	TRS_Bxxx.SOL	Token-Ring microcode image
d.	TRSxxxx.DEF	MIB tree definitions
e.	TRSxxxx.MIB	MIB definitions for private MIB
f.	TRSxxxx.TRP	MIB definitions for traps
g.	DTRCxxxx.MIB	MIB definitions for source-routing
h.	READ.ME	Release Notes

where xxx refers to the Release Number.

Refer to the READ.ME file in the diskette image for the latest information about the 8270 software and download procedures.

Items a through c are software modules that reside in the switch. Items d through g are network management files that should be given to your network administrator.

If you have an ATM UFC in your 8270, download the latest release of software for it also.

Download the Code into the 8270

There are three ways to download software to the 8270: "Initiating a Download with the System Request Menu" on page 6-2, "Serial Port or TFTP Downloading with the Download Menu" on page 6-3, and "BootP" on page 6-5.

Initiating a Download with the System Request Menu

Important: Before beginning, make sure that the baud rate of the terminal session and the 8270 are both set to 9600. Although this rate is slow, it helps prevent potential problems.

This section provides information on initiating the download procedure with the System Request Menu.

Follow these steps to begin a software upgrade:

- Step 1.** If you have not already done so, start a console session and advance to the Copyright panel, if possible.
- Step 2.** Press and release the **System Request** button. The console will display the System Request menu.

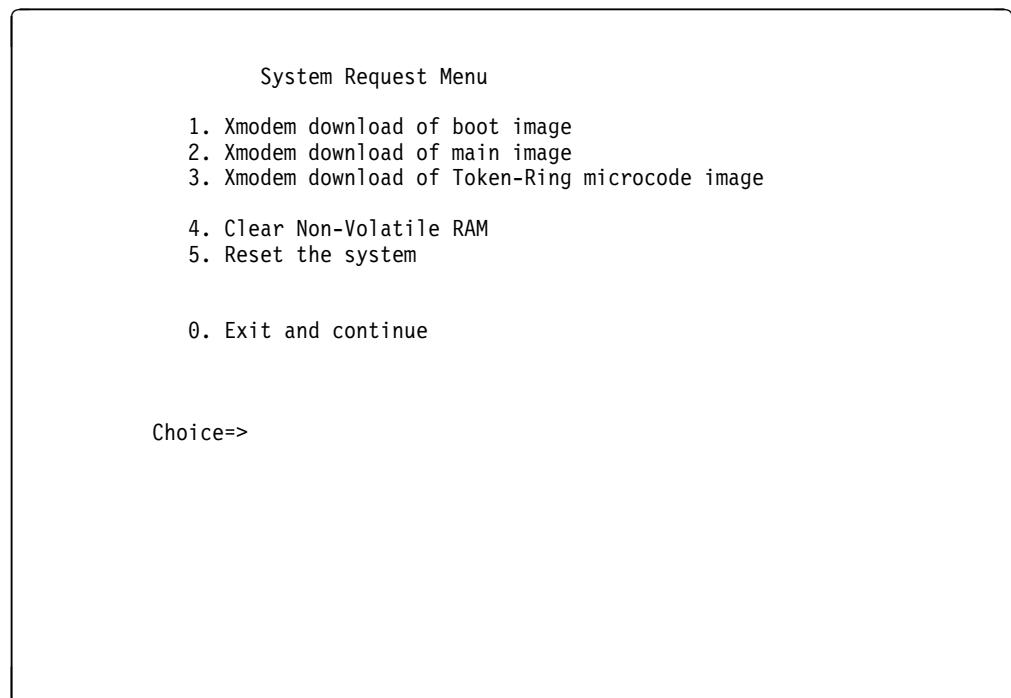

Figure 6-1. System Request Menu

- Step 3.** Select your download option from the console and continue with the procedure.
- Step 4.** The following messages appear:
SYSREQ: Beginning Xmodem download of main(or boot) image
SYSREQ: Waiting for binary file....
- Step 5.** Use a terminal emulator program on your PC to download the binary file using Xmodem protocol.
The download takes approximately 5 minutes at 9600 baud.
When the download is complete, the following messages appear:

```
SYSREQ: Beginning Xmodem download of main image
SYSREQ: Waiting for binary file.... Done
SYSREQ: Preparing Flash....Done.
SYSREQ: Saving Main Image into Flash...Done
```

SYSREQ: Press any key to return to System Request menu.

- Step 6.** Reset the switch after each module is loaded; this helps ensure error-free downloads. Select option 5 to reset the system.

Serial Port or TFTP Downloading with the Download Menu

Important: Before beginning, make sure that the baud rate of the terminal session and the 8270 are both set to 9600. Although this rate is slow, it helps prevent potential problems.

This section provides information on initiating the download procedure with the Download menu.

Follow these steps to begin a software upgrade:

- Step 1.** If you are downloading via the serial port, insert the upgrade disk in your terminal drive. Make sure that your terminal emulator supports Xmodem protocol.
- Step 2.** If you are downloading via TFTP, copy all three image files to the TFTP server and prepare the TFTP server.
- Step 3.** If you have not already done so, start a console session and advance to the Main Menu. For information on starting a console session, refer to *Planning, Configuration, and Operation*.
- Step 4.** Select **Download** on the Main Menu.

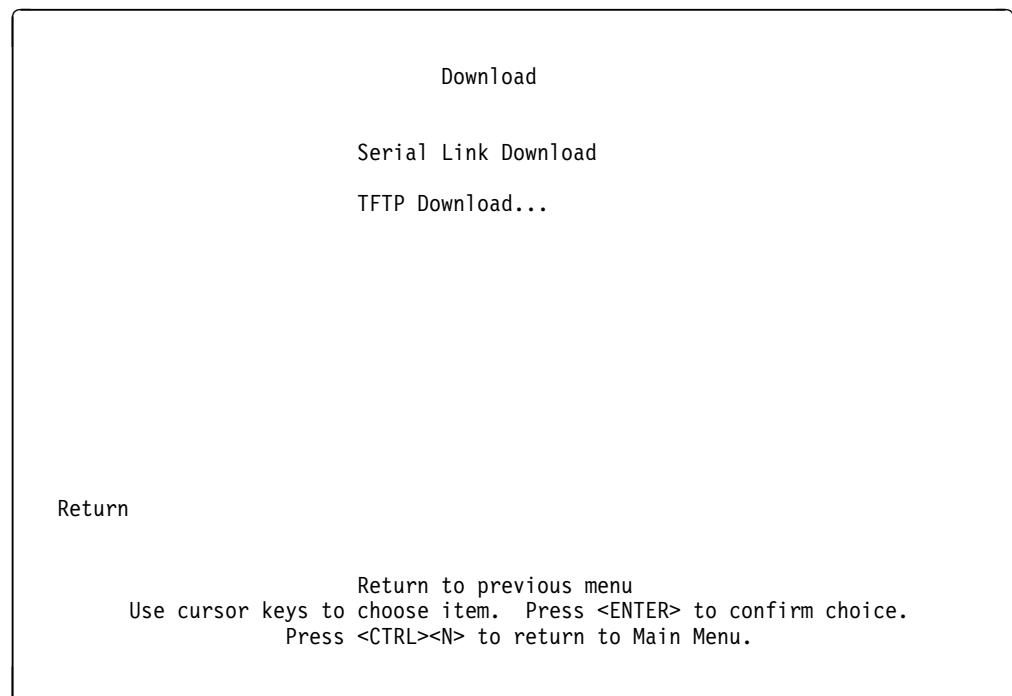

Figure 6-2. Download Menu

- Step 5.** When the Download menu appears (see Figure 6-2), select **Serial Link Download** or **TFTP Download...**
- Step 6.** If you chose Serial Link Download, go to step 8.
- Step 7.** If you chose TFTP Download, go to step 13.
- Step 8.** Select **Main Image, Boot Code, Token-Ring Microcode, UFC Image, or Other**. If you select UFC Image, you will be prompted to select the UFC for which you are downloading code.
- Step 9.** Confirm the download when you are prompted to do so by the following message:
- Please confirm new code download via serial port (Y or N):
- Step 10.** The following messages appear:
- Console: Beginning Xmodem download of main image
Console: Waiting for binary file....
- Step 11.** Use the file transfer function of your terminal emulator program to download the binary file using Xmodem protocol.
- The download takes approximately 5 minutes at 9600 baud.
- Attention:** Do not interrupt the download or the boot image will be corrupted and need to be reloaded. During the download, the 8270 OK LED will blink.
- When the download is complete, the following messages appear:
- Console: Beginning Xmodem download of main image
Console: Waiting for binary file.... Done
Console: Preparing Flash...Done.
Console: Saving Main Image into Flash...Done
- Please confirm switch reset (Y or N):
- Step 12.** Confirm the reset. The procedure is complete.
- Step 13.** When the TFTP Download panel appears (see Figure 6-3 on page 6-5), fill in the fields and then select **Execute Network Download**.
- Step 14.** Confirm the download when you see the message:
- Please confirm new code download via network (Y or N):
- Attention:** Do not interrupt the download or the boot image will be corrupted and need to be reloaded. During the download, the 8270 OK LED will be blinking.

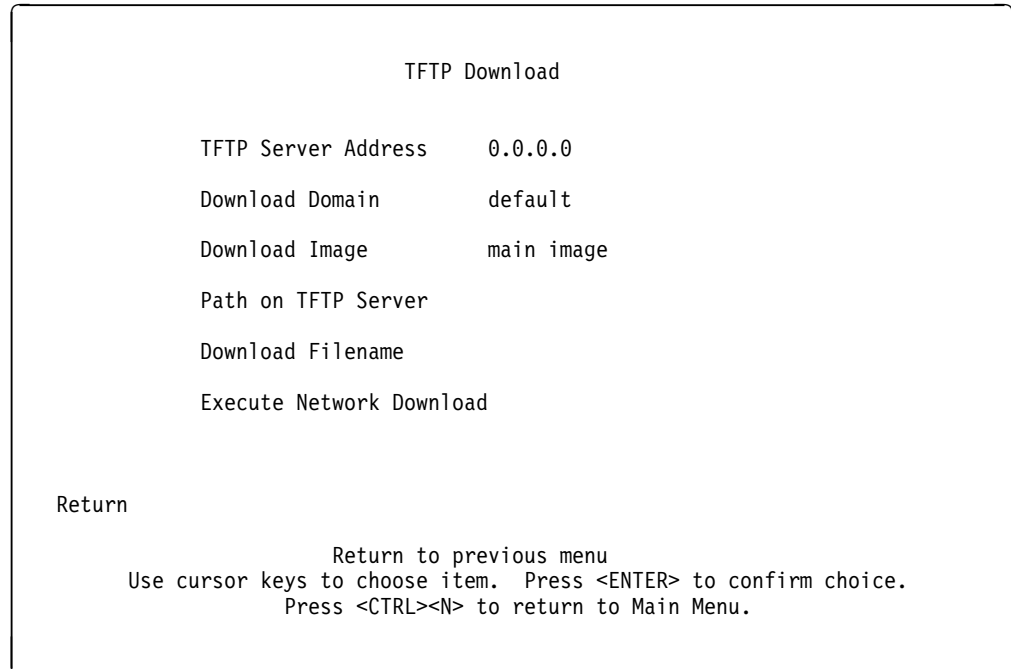

Figure 6-3. TFTP Download Panel

Step 15. Press **Enter** when you see the message:

Download complete - reset switch to activate new software.
Press <Enter> to continue.....

Step 16. Reset the 8270, as instructed, to activate the new code. Reset the switch after each module is loaded; this helps ensure error-free downloads.

BootP

The Bootstrap Protocol (referred to as *BootP*) function allows the 8270 to participate in RFC 951-compliant environments. BootP uses User Datagram Protocol (UDP) to formulate a network request to allow a device to configure its IP address for a given logical 8270.

Step 1. Edit the BOOTPTAB file on the BootP server (see “Editing the BOOTPTAB File” on page 6-7).

Step 2. Initiate the BootP daemon (*BOOTPD*) on the BootP server.

Step 3. Make sure that the IP State in the IP Configuration Menu is set to BootP When Needed or BootP Always.

Step 4. Initiate the BootP transfer by resetting the 8270. A BootP is automatically initiated after diagnostics have been completed.

Note: Do not configure multiple BootP servers to a single 8270.

The BootP sequence consists of IP address determination and bootfile selection, if configured, using BootP request and reply.

In order for you to utilize the BootP function, a BootP server must be configured on the network. This BootP server must reside on the same subnet as the 8270. A typical implementation might consist of a BootP daemon (*BOOTPD* or *IN.BOOTPD*) or something similar. *BOOTPD* reads a startup file called *BOOTPTAB*. This file

contains various strings that describe how BootP clients are configured. An entry is made in the BOOTPTAB file for each BootP client (in this case, the 8270) on the network. Figure 6-4 on page 6-7 displays an example of a BOOTPTAB file for configuring two 8270s.

The 8270 BootP function has been tested in the following environments:

- Solaris** with an HP version of CMU BOOTP
- Santa Cruz Operation (SCO**) UNIX with an SCO BOOTP
- LattisNet** DOS Network Management Station
- IBM NetView for AIX

Editing the BOOTPTAB File

Figure 6-4 shows an example of a BOOTPTAB file.

```
#Blank lines and lines beginning with '#' are ignored.
#Legend:
#      first field--hostname (may be full domain name)
#      bf--bootfile
#      bs--bootfile size
#      cs--cookie servers
#      ds--domain name servers
#      gw--gateway address list
#      ha--host hardware address
#      hd--bootfile home directory
#      hn--send hostname
#      ht--hardware type
#      im--impress servers
#      ip--host IP address
#      lg--log servers
#      lp--LPR servers
#      ns--IEN-116 name servers
#      rl--resource location protocol servers
#      sm--subnet mask
#      tc--template host (points to similar host entry)
#      to--time offset (seconds)
#      ts--time servers
#      vm--vendor magic cookie selector

#Be certain to include backslashes where they are needed.
#Define different master entries for each 8270 (or domain).

S82701:\
    hn:\
    ht=token-ring:\
    vm=rfc1048:\
    ha=0004AC281340:\
    ip=134.177.169.111:\
    sm=255.255.0.0:\
    gw=134.177.169.201:\
    bf=/etc/TRS_Bxxx.gz:

S82702:\
    hn:\
    ht=token-ring:\
    vm=rfc1048:\
    ha=1005A2B12A0:\
    ip=134.177.169.48:\
    sm=255.255.0.0:\
    gw=134.177.169.201:\
    bf=/etc/TRS_Bxxx.gz:
```

Figure 6-4. Example of a BOOTPTAB File

Configure the BOOTPTAB file to the 8270 to which the BootP server is attached. Associate the MAC address and the IP address for Domain 0 as listed in the Master Address Table (see “Viewing the Master Address Table” on page 4-3).

Note: Do not use the MAC address in the Switch Information panel.

The Master Address Table in Figure 4-3 on page 4-3 displays the address for Domain 0 (default). In the example given, the address for the 8270 is the *Switch Base MAC Address* (0004AC 281320) on the Switch Information panel (see Figure 3-4 on page 3-11). The address that is loaded for Domain 0 in the BOOTPTAB file is 0004AC 281340. If another 8270 is configured, the address associated with that 8270 is entered in the BOOTPTAB file in the BootP server associated with that 8270. (In this example, the second 8270 has the Domain 0 address 10005A 2B12A0 which corresponds to switch base address 10005A 2B1280)

If the 8270 has domains configured, a BootP server is attached to each configured domain. The BOOTPTAB file contains the address for that specific domain.

Note: BootP has a limitation with respect to the gateway entry. The server device IP address is written into the “gw” gateway address field when the configuration is downloaded. Thus, you must configure the gateway address on the 8270 at the end of the download sequence. Refer to your UNIX operating system environment manual for further information.

BootP and TFTP Limitations

- Do not configure multiple TFTP servers to download code updates using TFTP to a single 8270 (or to multiple domains).
- When you use domains, BootP configures the IP address of the BootP-connected network.
- The IBM BootP implementation does not need or handle any BootP extensions.
- If the download is interrupted or corrupted, you must download a new image using the serial port download (see “Serial Port or TFTP Downloading with the Download Menu” on page 6-3).
- If the network broadcast traffic is 200 packets per second or more, the TFTP request might not be initiated by the 8270. You must reset the 8270 and download a new image using the serial port download (see “Serial Port or TFTP Downloading with the Download Menu” on page 6-3).
- The BootP function might not work if BootP request and reply frames must cross Token-Ring segments.

Error Messages

During the BootP download procedure, the 8270 might encounter certain error conditions. When this occurs, the 8270 sends error messages to the console.

Appendix A. Planning Charts and Worksheets

The planning charts and worksheets on the following pages can be photocopied and used for planning the installation and configuration of the 8270s in your network.

8270 Cabling Chart (1 of 2)

Date:	Mounting: <input type="checkbox"/> Rack <input type="checkbox"/> Surface
Segment:	Building:
Unit No.:	Location:

Port (Type)	Management (EIA 232)
Cable Type	<input type="checkbox"/> Serial <input type="checkbox"/> Null Modem
Connect to: (Port Number, Device, and Location)	

UFC 1 Type:				
UFC Port (Base Port)	1 (1-1)	2 (1-2)	NA on 8270-800 (1-3) on 8270-600	NA on 8270-800 (1-4) on 8270-600
Cable Type				
Connect to:				

UFC 2 Type:				
UFC Port (Base Port)	1 (2-1)	2 (2-2)	3 (2-3)	4 (2-4)
Cable Type				
Connect to:				

UFC 3 Type:				
UFC Port (Base Port)	1 (3-1)	2 (3-2)	3 (3-3)	4 (3-4)
Cable Type				
Connect to:				

UFC 4 Type:				
UFC Port (Base Port)	1 (4-1)	2 (4-2)	3 (4-3)	4 (4-4)
Cable Type				
Connect to:				

8270 Cabling Chart (2 of 2)

UFC 5 Type:				
UFC Port (Base Port)	1 (5-1)	2 (5-2)	3 (5-3)	4 (5-4)
Cable Type				
Connect to:				

UFC 6 Type:				
UFC Port (Base Port)	1 (6-1)	2 (6-2)	3 (6-3)	4 (6-4)
Cable Type				
Connect to:				

8270-800 Only UFC 7 Type:				
UFC Port (Base Port)	1 (7-1)	2 (7-2)	3 (7-3)	4 (7-4)
Cable Type				
Connect to:				

8270-800 Only UFC 8 Type:				
UFC Port (Base Port)	1 (8-1)	2 (8-2)	3 (8-3)	4 (8-4)
Cable Type				
Connect to:				

8270 Cabling Chart (Part 2 of 2)

Switch Information Panel

“Viewing Switch Information” on page 3-11

Record the indicated information in the table.

System Name	
System Location	
System Contact	

Domain Name Panel

“Naming Domains” on page 3-14

Record in the table the name assigned to each domain.

Index	Domain Name
0	
1	
2	
3	
4	
5	
6	
7	
8	
9	
10	
11	
12	
13	
14	
15	

Domain Configuration Panel

“Configuring Domains” on page 3-13

Record in the table the name of the domain associated with each port.

Port	Domain Name
1-1	
1-2	
1-3 (8270-600 only)	
1-4 (8270-600 only)	
2-1	
2-2	
2-3	
2-4	
3-1	
3-2	
3-3	
3-4	
4-1	
4-2	
4-3	
4-4	
5-1	
5-2	
5-3	
5-4	
6-1	
6-2	
6-3	
6-4	
7-1 (8270-800 only)	
7-2 (8270-800 only)	
7-3 (8270-800 only)	
7-4 (8270-800 only)	
8-1 (8270-800 only)	
8-2 (8270-800 only)	
8-3 (8270-800 only)	
8-4 (8270-800 only)	

IP Configuration Panel

“Setting Up IP Addresses” on page 3-15

Domain Name	Parameter	Value
	IP Address Default: 0.0.0.0	____.____.____.____
	Default Gateway Default: 0.0.0.0	____.____.____.____
	Subnet Mask Default: 0.0.0.0	____.____.____.____
	IP State Default: BOOTP When Needed	_____
	IP Address Default: 0.0.0.0	____.____.____.____
	Default Gateway Default: 0.0.0.0	____.____.____.____
	Subnet Mask Default: 0.0.0.0	____.____.____.____
	IP State Default: BOOTP When Needed	_____
	IP Address Default: 0.0.0.0	____.____.____.____
	Default Gateway Default: 0.0.0.0	____.____.____.____
	Subnet Mask Default: 0.0.0.0	____.____.____.____
	IP State Default: BOOTP When Needed	_____
	IP Address Default: 0.0.0.0	____.____.____.____
	Default Gateway Default: 0.0.0.0	____.____.____.____
	Subnet Mask Default: 0.0.0.0	____.____.____.____
	IP State Default: BOOTP When Needed	_____

Make additional copies of this page if you have more than four domains.

SNMP Configuration Menu

“SNMP Network Management” on page 3-17

Send Authentication-Failure Traps	Yes	No
Set to:		

SNMP—Community Strings Panel

“Creating Communities” on page 3-19

Index	Community Name	Mode	
		R	W
1			
2			
3			
4			
5			
6			
7			
8			
9			
10			

Note:

- R=Read
- W=Read/Write

SNMP—Trap Receivers Panel (1 of 2)

“Creating Trap Receivers” on page 3-20

Domain	Index	IP Address	Trap Community Name
	1	____.____.____.____	
	2	____.____.____.____	
	3	____.____.____.____	
	4	____.____.____.____	
	5	____.____.____.____	
	6	____.____.____.____	
	7	____.____.____.____	
	8	____.____.____.____	
	9	____.____.____.____	
	10	____.____.____.____	
	11	____.____.____.____	
	12	____.____.____.____	
	13	____.____.____.____	
	1	____.____.____.____	
	2	____.____.____.____	
	3	____.____.____.____	
	4	____.____.____.____	
	5	____.____.____.____	
	6	____.____.____.____	
	7	____.____.____.____	
	8	____.____.____.____	
	9	____.____.____.____	
	10	____.____.____.____	
	11	____.____.____.____	
	12	____.____.____.____	
	13	____.____.____.____	

Note: The trap receivers address is the address of the workstations that receive SNMP errors.

SNMP—Trap Receivers Panel (2 of 2)

“Creating Trap Receivers” on page 3-20

Domain	Index	IP Address	Trap Community Name
	1	____.____.____.____	
	2	____.____.____.____	
	3	____.____.____.____	
	4	____.____.____.____	
	5	____.____.____.____	
	6	____.____.____.____	
	7	____.____.____.____	
	8	____.____.____.____	
	9	____.____.____.____	
	10	____.____.____.____	
	11	____.____.____.____	
	12	____.____.____.____	
	13	____.____.____.____	
	1	____.____.____.____	
	2	____.____.____.____	
	3	____.____.____.____	
	4	____.____.____.____	
	5	____.____.____.____	
	6	____.____.____.____	
	7	____.____.____.____	
	8	____.____.____.____	
	9	____.____.____.____	
	10	____.____.____.____	
	11	____.____.____.____	
	12	____.____.____.____	
	13	____.____.____.____	

Note: The trap receivers address is the address of the workstations that receive SNMP errors.

Make additional copies of this page if you have more than four domains.

Spanning Tree Panel

“Transparent Bridge Spanning Tree” on page 3-21

Domain	Parameter	Value
	Participate in Spanning Tree Default: No	802.1d ____ No ____
	Switch Priority Range: 0 to 65 535 Default: 32 768	
	Switch Hello Time Range (in seconds): 1 to 10 Default: 2	
	Switch Maximum Message Age Range (in seconds): 6 to 40 Default: 20	
	Switch Forward Delay Range (in seconds): 4 to 30 Default: 15	
	Participate in Spanning Tree Default: No	802.1d ____ No ____
	Switch Priority Range: 0 to 65 535 Default: 32 768	
	Switch Hello Time Range (in seconds): 1 to 10 Default: 2	
	Switch Maximum Message Age Range (in seconds): 6 to 40 Default: 20	
	Switch Forward Delay Range (in seconds): 4 to 30 Default: 15	
	Participate in Spanning Tree Default: No	802.1d ____ No ____
	Switch Priority Range: 0 to 65 535 Default: 32 768	
	Switch Hello Time Range (in seconds): 1 to 10 Default: 2	
	Switch Maximum Message Age Range (in seconds): 6 to 40 Default: 20	
	Switch Forward Delay Range (in seconds): 4 to 30 Default: 15	
	Participate in Spanning Tree Default: No	802.1d ____ No ____
	Switch Priority Range: 0 to 65 535 Default: 32 768	
	Switch Hello Time Range (in seconds): 1 to 10 Default: 2	
	Switch Maximum Message Age Range (in seconds): 6 to 40 Default: 20	
	Switch Forward Delay Range (in seconds): 4 to 30 Default: 15	

Make additional copies of this page if you have more than four domains.

Spanning Tree—Port Priority and Path Cost Panel

“Port Parameters” on page 3-23

Record in the table the cost of each port.

Range: 1 to 65 535

Default: 62

Record in the table the priority for each port.

Range: 0 to 255

Default: 128

Port:	1-1	1-2	1-3 (8270-600 only)	1-4 (8270-600 only)	2-1	2-2	2-3	2-4
Cost:								
Priority:								

Port:	3-1	3-2	3-3	3-4	4-1	4-2	4-3	4-4
Cost:								
Priority:								

Port:	5-1	5-2	5-3	5-4	6-1	6-2	6-3	6-4
Cost:								
Priority:								

Port:	7-1 (8270-800 only)	7-2 (8270-800 only)	7-3 (8270-800 only)	7-4 (8270-800 only)	8-1 (8270-800 only)	8-2 (8270-800 only)	8-3 (8270-800 only)	8-4 (8270-800 only)
Cost:								
Priority:								

Path Cost = 1000/LAN speed in Mbps

Port Configuration Panel (1 of 2)

“Configuring Token-Ring Ports” on page 3-25

Fill in the appropriate boxes to define the characteristics of each port.

Port:	1-1	1-2	1-3 (8270-600 only)	1-4 (8270-600 only)	2-1	2-2	2-3	2-4
Switching Mode								
Type								
State								
Config Type								
Speed								
Mode								
Duplex								
Config Loss								

Port:	3-1	3-2	3-3	3-4	4-1	4-2	4-3	4-4
Switching Mode								
Type								
State								
Config Type								
Speed								
Mode								
Duplex								
Config Loss								

Port Configuration Panel (2 of 2)

“Configuring Token-Ring Ports” on page 3-25

Fill in the appropriate boxes to define the characteristics of each port.

Port:	5-1	5-2	5-3	5-4	6-1	6-2	6-3	6-4
Switching Mode								
Type								
State								
Config Type								
Speed								
Mode								
Duplex								
Config Loss								

Port:	7-1 (8270-800 only)	7-2 (8270-800 only)	7-3 (8270-800 only)	7-4 (8270-800 only)	8-1 (8270-800 only)	8-2 (8270-800 only)	8-3 (8270-800 only)	8-4 (8270-800 only)
Switching Mode								
Type								
State								
Config Type								
Speed								
Mode								
Duplex								
Config Loss								

Note: The port Config Type must be **Fixed** if you want to change port Speed, Mode, or Duplex.

Source-Route Configuration Panel

“Assigning or Changing LAN Segment Numbers” on page 3-33

Record the LAN segment numbers assigned to each domain.

Index	Domain Name	LAN Segment Number
1		
2		
3		
4		
5		
6		
7		
8		
9		
10		
11		
12		
13		
14		
15		
16		

Internal Source-Route Bridge Configuration Menu

“Internal Source-Route Bridge Configuration” on page 3-34

Record the internal bridge number and mark the box corresponding to the state of the bridge.

Bridge Number (0 - F)	State
	<input type="checkbox"/> Enabled <input type="checkbox"/> Disabled.

LAN Segment Bridging Parameters Panel

“Displaying LAN Segment Bridging Parameters” on page 3-35

Record the bridging parameters for each LAN segment.

Segment Number	Domain Name	Bridged Segment Forwarding	ARE Tx Hop Cnt	ARE Rx Hop Cnt	STE Tx Hop Cnt	STE Rx Hop Cnt	Maximum Frame Size
		<input type="checkbox"/> Enabled <input type="checkbox"/> Disabled					
		<input type="checkbox"/> Enabled <input type="checkbox"/> Disabled					
		<input type="checkbox"/> Enabled <input type="checkbox"/> Disabled					
		<input type="checkbox"/> Enabled <input type="checkbox"/> Disabled					
		<input type="checkbox"/> Enabled <input type="checkbox"/> Disabled					
		<input type="checkbox"/> Enabled <input type="checkbox"/> Disabled					
		<input type="checkbox"/> Enabled <input type="checkbox"/> Disabled					
		<input type="checkbox"/> Enabled <input type="checkbox"/> Disabled					

Source-Route Bridge Spanning Tree Configuration Panel

“Source-Route Bridge Spanning Tree Configuration” on page 3-38

Record the Spanning Tree parameters for the internal source-route bridge.

Parameter	Value
SRB Spanning Tree Mode	<input type="checkbox"/> Manual <input type="checkbox"/> Automatic
SRB Priority Range: 0 to 65 535 Default: 32 768	
SRB Hello Time Range: 0 to 10 sec Default: 2 sec	
SRB Maximum Message Age Range: 6 to 40 sec Default: 6 sec	
SRB Forwarding Delay Range: 4 to 30 sec Default: 4 sec	

Source-Route Bridge Path Cost Panel

“Source-Route Bridge Path Cost” on page 3-40

Record the path cost for each LAN segment. This is applicable only if the SRB Spanning Tree mode is Automatic.

Segment Number	Domain Name	Segment Path Cost Range: 0 to 65 535 Default: 62

Source-Route Bridge Manual Spanning Tree Parameters Panel

“Source-Route Bridge (SRB) Manual Spanning Tree Parameters” on page 3-41

Record the forwarding state of each source-route bridge segment. This is applicable only if the SRB Spanning Tree mode is Manual.

Segment Number	Domain Name	Single-route Bcast Frames
		<input type="checkbox"/> Forward <input type="checkbox"/> Block
		<input type="checkbox"/> Forward <input type="checkbox"/> Block
		<input type="checkbox"/> Forward <input type="checkbox"/> Block
		<input type="checkbox"/> Forward <input type="checkbox"/> Block
		<input type="checkbox"/> Forward <input type="checkbox"/> Block
		<input type="checkbox"/> Forward <input type="checkbox"/> Block
		<input type="checkbox"/> Forward <input type="checkbox"/> Block
		<input type="checkbox"/> Forward <input type="checkbox"/> Block

TokenProbe Configuration Panel

“Configuring TokenProbe (Token-Ring Ports only)” on page 3-46

TokenProbe Port:_____

Note: You can configure any of the Token-Ring ports as the TokenProbe port. However, this port will then be a dedicated TokenProbe port. Do not select a heavily used port as the TokenProbe port.

TokenPipe Configuration Panel

“Configuring TokenPipe (Token-Ring Ports only)” on page 3-48

Write the port numbers in each TokenPipe in the table.

TokenPipe	Ports
1	
2	
3	
4	

Configure Filters Panel

“Configuring Filters” on page 3-43

Filter Number	MAC Address	Filter Type	Entry Ports	Exit Ports
1				
2				
3				
4				
5				
6				
7				
8				
9				
10				
11				
12				
13				
14				
15				
16				
17				
18				
19				
20				
21				
22				
23				
24				
25				
26				
27				
28				
29				
30				

Make additional copies of this page if you have more than 30 filters.

Configure Port Security Mode Panel

“Configuring Port Security Mode” on page 3-45

Record in the table the security mode for each port.

Port	Security Mode
1-1	
1-2	
1-3 (8270-600 only)	
1-4 (8270-600 only)	
2-1	
2-2	
2-3	
2-4	
3-1	
3-2	
3-3	
3-4	
4-1	
4-2	
4-3	
4-4	
5-1	
5-2	
5-3	
5-4	
6-1	
6-2	
6-3	
6-4	
7-1 (8270-800 only)	
7-2 (8270-800 only)	
7-3 (8270-800 only)	
7-4 (8270-800 only)	
8-1 (8270-800 only)	
8-2 (8270-800 only)	
8-3 (8270-800 only)	
8-4 (8270-800 only)	

Port Address Table Aging Panel

“Configuring Port Address Aging” on page 3-28

Record in the table the aging time and demand aging level for each port.

Port	Aging Time	Demand Aging Level
1-1		
1-2		
1-3 (8270-600 only)		
1-4 (8270-600 only)		
2-1		
2-2		
2-3		
2-4		
3-1		
3-2		
3-3		
3-4		
4-1		
4-2		
4-3		
4-4		
5-1		
5-2		
5-3		
5-4		
6-1		
6-2		
6-3		
6-4		
7-1 (8270-800 only)		
7-2 (8270-800 only)		
7-3 (8270-800 only)		
7-4 (8270-800 only)		
8-1 (8270-800 only)		
8-2 (8270-800 only)		
8-3 (8270-800 only)		
8-4 (8270-800 only)		

Master Address Table Aging Panel

“Master Address Table Aging” on page 3-30

Record the Master Address Table Aging parameters.

Parameter	Value
Address Aging Time Range: 0 to 9999 min Default: 5 min.	
Demand Aging Level Range: 50%, 60%, 70%, 80%, 90%, or disable Default: 90%	

Switching Mode Threshold

“Switching Mode Threshold (Token-Ring Ports only)” on page 3-49

Record the Switching Mode Threshold parameters.

Parameter	Value
Error-rate high threshold Range: 0% to 100% Default: 10%	
Error-rate low threshold Range: 0% to 100% Default: 1%	
Error-rate trend Range: 0% to 100% Default: 1%	
Error Rate Sample Period Range: 5 to 120 min Default: 10 sec	

Password Panel

“Password” on page 3-51

Record the indicated passwords.

	Current Password	New Password
Read Only		
Read/Write		

Serial Configuration Panel

“Serial Link Configuration” on page 3-54

Mark the appropriate box to indicate whether the function is disabled or enabled.

Function	Enabled	Disabled
Hardware Flow Control		
Software Flow Control		
Autobaud upon Break		

Mark the appropriate box to select the console baud rate.

Default: 9600

Baud Rate	1200	2400	4800	9600	19200	38400	57600	Autobd
Set to:								

Telnet Configuration Panel

“Telnet Configuration” on page 3-55

Write in the number of sessions allowed.

Number of Telnet Sessions Allowed	
-----------------------------------	--

Check the appropriate box.

Disallow New Telnet Session	Yes	No
Set to:		

Adapter Address to Physical Location

Adapter Address	Physical Location	Device Identification	Segment Number	Hub/Switch Unit Number

Physical Location to Adapter Address

Physical Location	Adapter Address	Device Identification	Segment Number	Hub/Switch Unit Number

Appendix B. Menus and Panels Index

The following lists provides the names of all the menus and panels available on the 8270 management and configuration tool. The page numbers appearing after each title refer to the page in the manual where that menu or panel is described.

Configuration Menus

Copyright Panel (3-8)

Main Menu (3-9)

Configuration Menu (3-10)

- Switch Information (3-11)
- Domain Configuration (3-13)
 - Domain Names (3-14)
- IP Configuration for Domain (3-15)
- SNMP Configuration (3-18)
 - Community Strings (3-19)
 - Trap Receivers (3-20)
- Spanning Tree for Domain (3-21)
 - Port Parameters (3-23)
- Token-Ring Port Configuration (3-25)
- Address Aging (3-28)
 - Port Address Table Aging (3-29)
 - Master Address Table Aging (3-30)
- Source-Route Configuration (3-33)
 - Internal Source-Route Bridge (SRB) Configuration (3-34)
 - LAN Segment Bridging Parameters (3-35)
 - Change LAN Segment Bridging Parameters (3-36)
 - Source-Route Bridge Spanning Tree Configuration (3-38)
 - Source-Route Bridge Path Cost (3-40)
 - Source-Route Bridge Manual Spanning Tree Parameters (3-41)
- MAC Filter & Port Security... (3-42)
 - Configure Filters (3-43)
 - Configure Port Security Mode (3-45)
- TokenProbe Configuration (3-46)
- TokenPipe Configuration (3-48)
- Switching Mode Threshold (3-49)
- Password (3-51)

- Console Configuration (3-53)
 - Serial Link Configuration (3-54)
 - Telnet Configuration (3-55)
 - Telenet Sessions (3-56)

Management and Statistics Panels

Main Menu (3-9)

Status/Statistics Menu (4-1)

- Module Information (4-2)
- Master Address Table (4-3)
- Master Route Descriptor Table (4-4)
- Switch Statistics (4-5)
- Message Log Information (4-7)
- Domain Address Table for Domain (4-8)
- Domain Route Descriptor Table for Domain (4-9)
- Domain Statistics for Domain (4-10)
- Transparent Spanning Tree for Domain (4-11)
- Port Status (4-14)
- TokenPipe Status (4-16)
- Port N Address Table (4-17)
- Port N Route Descriptor Table (4-18)
- Port N Statistics (4-19)
- Port N Filters (4-23)
- Source-Route Bridge Spanning Tree Status (4-24)
- Source-Route Bridge LAN Segment Selection (4-26)
- Source-Route Bridging (SRB) Statistics (4-27)

Appendix C. MAC Address Template

The MAC address is 12-digit, hexadecimal number represented as pairs of hexadecimal digits separated by periods (that is, xx.xx.xx.xx.xx.xx). The *Base address* is labeled on the front of the processor card. Each port and domain on the 8270 is assigned a MAC address as follows:

8270-600 Port	8270-800 Port	MAC Address
Base	Base	Base address
	1-1	Base address+X'01'
	1-2	Base address+X'02'
	2-1	Base address+X'03'
	2-2	Base address+X'04'
	2-3	Base address+X'05'
	2-4	Base address+X'06'
1-1	3-1	Base address+X'07'
1-2	3-2	Base address+X'08'
1-3	3-3	Base address+X'09'
1-4	3-4	Base address+X'0A'
2-1	4-1	Base address+X'0B'
2-2	4-2	Base address+X'0C'
2-3	4-3	Base address+X'0D'
2-4	4-4	Base address+X'0E'
3-1	5-1	Base address+X'0F'
3-2	5-2	Base address+X'10'
3-3	5-3	Base address+X'11'
3-4	5-4	Base address+X'12'
4-1	6-1	Base address+X'13'
4-2	6-2	Base address+X'14'
4-3	6-3	Base address+X'15'
4-4	6-4	Base address+X'16'
5-1	7-1	Base address+X'17'
5-2	7-2	Base address+X'18'
5-3	7-3	Base address+X'19'
5-4	7-4	Base address+X'1A'
6-1	8-1	Base address+X'1B'
6-2	8-2	Base address+X'1C'
6-3	8-3	Base address+X'1D'
6-4	8-4	Base address+X'1E'
	Reserved	Base address+X'1F'
	Domain 00	Base address+X'20'
	Domain 01	Base address+X'21'

8270-600 Port	8270-800 Port	MAC Address
	Domain 02	Base address+X' 22'
	Domain 03	Base address+X' 23'
	Domain 04	Base address+X' 24'
	Domain 05	Base address+X' 25'
	Domain 06	Base address+X' 26'
	Domain 07	Base address+X' 27'
	Domain 08	Base address+X' 28'
	Domain 09	Base address+X' 29'
	Domain 10	Base address+X' 2A'
	Domain 11	Base address+X' 2B'
	Domain 12	Base address+X' 2C'
	Domain 13	Base address+X' 2D'
	Domain 14	Base address+X' 2E'
	Domain 15	Base address+X' 2F'
	Reserved	Base address+X' 30' through Base address+X' 5F'

Appendix D. Internal Port Mapping

Internal Port	8270-600	8270-800	8272-108	8772-216	8272 LAN Switch Modules
1	-	1-1	1	1	1
2	-	1-2	2	2	2
3	-	2-1	3	3	3
4	-	2-2	4	4	4
5	-	2-3	5	5	5
6	-	2-4	6	6	6
7	1-1	3-1	7	7	7
8	1-2	3-2	8	8	8
9	1-3	3-3	-	9	-
10	1-4	3-4	-	10	-
11	2-1	4-1	-	11	-
12	2-2	4-2	-	12	-
13	2-3	4-3	-	13	1-1
14	2-4	4-4	-	14	1-2
15	3-1	5-1	-	15	1-3
16	3-2	5-2	-	16	1-4
17	3-3	5-3	-	1-1	2-1
18	3-4	5-4	-	1-2	2-2
19	4-1	6-1	-	1-3	2-3
20	4-2	6-2	-	1-4	2-4
21	4-3	6-3	1-1	2-1	3-1
22	4-4	6-4	1-2	2-2	3-2
23	5-1	7-1	1-3	2-3	3-3
24	5-2	7-2	1-4	2-4	3-4
25	5-3	7-3			4-1
26	5-4	7-4			4-2
27	6-1	8-1			4-3
28	6-2	8-2			4-4
29	6-3	8-3			Integrated ATM
30	6-4	8-4			

Internal Port	LEC
32	X01
.	.
.	.
.	.
63	X32
64	Y01
.	.
.	.
.	.
95	Y32

Note: X is the slot number of the first ATM UFC and Y is the slot number of the second ATM UFC.

Glossary

This glossary includes terms and definitions from the *IBM Dictionary of Computing* (New York; McGraw-Hill, Inc., 1994).

- The symbol (A) identifies definitions from the *American National Standard Dictionary for Information Systems*, ANSI X3.172-1990, copyright 1990 by the American National Standards Institute (ANSI). Copies can be purchased from the American National Standards Institute, 1430 Broadway, New York, New York 10018.
- The symbol (E) identifies definitions from the ANSI/EIA Standard-440-A, *Fiber Optic Terminology*.
- The symbol (I) identifies definitions from published parts of the *Information Technology Vocabulary*, developed by Subcommittee 1, Joint Technical Committee 1, of the International Organization for Standardization and the International Electrotechnical Commission (ISO/IEC JTC1/SC1).

- The symbol (T) identifies definitions from draft international standards, committee drafts, and working papers being developed by ISO/IEC JTC1/SC1.

The following cross-references are used in this glossary:

Contrast with: This refers to a term that has an opposed or substantively different meaning.

Synonym for: This indicates that the term has the same meaning as a preferred term, which was defined in its correct place in the glossary.

Synonymous with: This is a backward reference from a defined term to all other terms that have the same meaning.

See: This refers the reader to multiple-word terms that have the same last word.

See also: This refers the reader to related terms that have a related, but not synonymous, meaning.

A

access unit. A unit that allows multiple attaching devices access to a token-ring network at a central point such as a wiring closet or in an open work area. See *multistation access unit*.

adapter. In a communicating device, a circuit card that, with its associated software and/or microcode, enables the device to communicate over the network.

adaptive switching mode. In a LAN switch, the capability to alternate automatically between Cut-Through switching mode and Store-and-Forward switching mode, based on user-specified soft-error thresholds. See also *Cut-Through switching mode* and *Store-and-Forward switching mode*.

address. In data communication, the unique code assigned to each device or workstation connected to a network.

address resolution. A method for mapping network layer addresses onto media-specific addresses. See also *Address Resolution Protocol (ARP)*.

Address Resolution Protocol (ARP). A protocol that dynamically maps between Internet addresses, baseband adapter addresses, X.25 addresses, and token-ring adapter addresses on a local area network.

agent. In the client-server model, the part of the system that performs information preparation and exchange on behalf of a client or server application. See also *client-server model* and *network management station (NMS)*.

AIX operating system. IBM's implementation of the UNIX operating system. See *UNIX operating system*.

American National Standards Institute (ANSI). An organization consisting of producers, consumers, and general interest groups, that establishes the procedures by which accredited organizations create and maintain voluntary industry standards in the United States. (A)

ANSI. American National Standards Institute.

ARP. Address resolution protocol.

ATM. Asynchronous transfer mode.

attaching device. Any device that is physically connected to a network and can communicate over the network. See *ring attaching device*.

B

backbone. (1) In a local area network multiple-bridge ring configuration, a high-speed link to which the rings are connected by means of bridges or routers. A backbone can be configured as a bus or as a ring. (2) In a wide area network, a high-speed link to which nodes or data switching exchanges (DSEs) are connected.

backup path. In an IBM Token-Ring Network, an alternative path for signal flow through access units and their main ring path cabling. The backup path allows recovery of the operational portion of the network while problem determination procedures are being performed.

bandwidth. (1) The difference, expressed in hertz, between the highest and the lowest frequencies of a range of frequencies. For example, analog transmission by recognizable voice telephone requires a bandwidth of about 3000 hertz (3 kHz). (2) The bandwidth of an optical link designates the information-carrying capacity of the link and is related to the maximum bit rate that a fiber link can support.

baud. (1) A unit of signaling speed equal to the number of discrete conditions or signal events per second; for example, one baud equals one-half dot cycle per second in Morse code, one bit per second in a train of binary signals, and one 3-bit value per second in a train of signals each of which can assume one of eight different states. (A) (2) In asynchronous transmission, the unit of modulation rate corresponding to one unit interval per second; that is, if the duration of the unit interval is 20 milliseconds, the modulation rate is 50 baud. (A)

best-effort delivery. Unreliable connectionless delivery of datagrams in a network. Reliability at link levels is not provided.

BootP. Bootstrap Protocol.

bootstrap. (1) A sequence of instructions whose execution causes additional instructions to be loaded and executed until the complete computer program is in storage. (T) (2) A technique or device designed to bring itself into a desired state by means of its own action, for example, a machine routine whose first few instructions are sufficient to bring the rest of itself into the computer from an input device. (A)

bridge. (1) An attaching device that connects two LAN segments to allow the transfer of information from one LAN segment to the other. A bridge can connect the LAN segments directly by network adapters and software in a single device, or it can connect network adapters in two separate devices through software and use of a telecommunications link between the two adapters. (2) A functional unit that connects two LANs

that use the same logical link control (LLC) procedures but may use the same or different medium access control (MAC) procedures. (T) Contrast with *gateway* and *router*.

Note: A bridge connects networks or systems of the same or similar architectures, whereas a gateway connects networks or systems of different architectures.

bridge ID. The bridge label combined with the adapter address of the adapter connecting the bridge to the LAN segment with the lowest LAN segment number; it is used by the automatic single-route broadcast function in IBM bridge programs.

bridge number. The bridge identifier that the user specifies in the bridge program configuration file. The bridge number distinguishes among parallel bridges. See also *parallel bridge*.

bridging. The forwarding of a frame from one local area network segment to another. The destination is based upon the medium access control (MAC) sublayer address encoded in the destination address field of the frame header.

broadcast. (1) Transmission of the same data to all destinations. (T) (2) Simultaneous transmission of the same data to more than one destination. (3) A packet delivery system where a copy of a given packet is given to all hosts attached to the network. Broadcast can be implemented in hardware (Ethernet, for example) or software. Contrast with *multicast*.

BTU. British thermal unit.

byte. (1) A string that consists of a number of bits, treated as a unit, and representing a character. (T) (2) A binary character operated upon as a unit and usually shorter than a computer word. (A) (3) A group of 8 adjacent binary digits that represent one EBCDIC character. (4) See *n-bit byte*. See also *bit*.

C

C. Celsius.

cable segment. A section of cable between components or devices on a network. A segment can consist of a single patch cable, multiple patch cables connected together, or a combination of building cable and patch cables connected together. See *LAN segment*, *ring segment*.

channel-attached. (1) Pertaining to the connection of devices directly by data channels (I/O channels) to a computer. (2) Pertaining to devices connected to a controlling unit by cables rather than by

telecommunication lines. See also *local*. Contrast with *telecommunication-attached*.

client. (1) A user. (2) A functional unit that receives shared services from a server. (T)

client-server model. A common way to describe network services and the model user processes (programs) of those services.

command. (1) A request for performance of an operation or execution of a program. (2) A character string from a source external to a system that represents a request for system action.

community. An administrative relationship between Simple Network Management Protocol (SNMP) entities.

community name. An opaque string of octets identifying a community.

configuration. (1) The manner in which the hardware and software of an information processing system are organized and interconnected. (T) (2) The devices and programs that make up a system, subsystem, or network. (3) The task of defining the hardware and software characteristics of a system or subsystem. (4) See also *system configuration*.

configuration parameters. Variables in a configuration definition, the values of which characterize the relationship of a product, such as a bridge, to other products in the same network.

congestion. See *network congestion*.

connect. In a LAN, to physically join a cable from a station to an access unit or network connection point. Contrast with *attach*.

connection. (1) In TCP/IP, the path between two protocol applications that provides reliable data stream delivery service. In Internet, a connection extends from a TCP application on one system to a TCP application on another system. (2) The path between two protocol functions, usually located in different machines, that provides reliable data delivery service.

connectivity. (1) The capability of a system or device to be attached to other systems or devices without modification. (T) (2) The capability to attach a variety of functional units without modifying them.

connector. A means of establishing electrical flow.

controller. A unit that controls input/output operations for one or more devices.

CRC. Cyclic redundancy check.

cursor. (1) A movable, visible mark used to indicate the position at which the next operation will occur on a display surface. (2) A unique symbol that identifies a character position in a screen display, usually the character position at which the next character to be entered from the keyboard will be displayed.

customize. Defining and activating a configuration, and changing system parameters to meet user requirements.

Cut-Through switching mode. In LAN switches, an architecture that allows a switch to transmit a frame out of the destination port after it has received the destination address header. The switch does not have to wait for the whole frame to be received in order to begin transmission. This cuts down drastically on latency. Contrast with *Store-and-Forward switching mode*.

D

data terminal equipment (DTE). (1) That part of a data station that serves as a data source, data sink, or both. (I) (A) (2) Equipment that sends or receives data, or both.

data terminal ready (DTR). A signal to the modem used with the EIA 232 protocol.

database. A collection of data with a given structure for accepting, storing, and providing, on demand, data for multiple users. (T)

datagram. (1) In packet switching, a self-contained packet, independent of other packets, that carries information sufficient for routing from the originating data terminal equipment (DTE) to the destination DTE without relying on earlier exchanges between the DTEs and the network. (I) (2) In TCP/IP, the basic unit of information passed across the Internet environment. A datagram contains a source and destination address along with the data. An Internet Protocol (IP) datagram consists of an IP header followed by the transport layer data. See also *packet* and *segment*. (3) A particular type of information encapsulation, at the network layer of the adapter protocol. No explicit acknowledgment for the information is sent by the receiver. Transmission relies on the best effort of the link layer. See also *best-effort delivery*.

default. Pertaining to an attribute, value, or option that is assumed when none is explicitly specified. (I)

destination. Any point or location, such as a node, station, or particular terminal, to which information is to be sent.

destination address. A field in the medium access control (MAC) frame that identifies the physical location to which information is to be sent. Contrast with *source address*.

device. (1) An input/output unit such as a terminal, display, printer, or telephone. See also *attaching device*. (2) A physical entity attached to the network that requires data transportation service.

device identifier (ID). An 8-bit identifier that uniquely identifies a physical I/O device.

diagnostics. The process of investigating the cause or the nature of a condition or problem in a product or system.

digital. (1) Pertaining to data in the form of digits. (A) Contrast with *analog*. (2) Pertaining to data consisting of numerical values or discrete units.

directory. A table of identifiers and references to the corresponding items of data. (I) (A)

directory service (DS). An application service element that translates the symbolic names used by application processes into the complete network addresses used in an OSI environment. (T)

directory services (DS). A control point component of an APPN node that maintains a directory and provides the location of network resources.

disable. To make nonfunctional.

disabled. (1) Pertaining to a state of a processing unit that prevents the occurrence of certain types of interruptions. (2) Pertaining to the state in which a transmission control unit or audio response unit cannot accept incoming calls on a line. (3) Nonoperational or nonfunctional.

domain. That part of a computer network in which the data processing resources are under common control. (T)

DRAM. Dynamic random access memory.

DTE. Data terminal equipment. (A)

DTR. Data terminal ready.

duplex. Pertaining to communication in which data can be sent and received at the same time. Synonymous with *full-duplex*. Contrast with *half-duplex*.

E

EEPROM. Electrically erasable programmable read-only memory.

EIA. Electronic Industries Association.

EIA-232. In data communications, a specification of the Electronic Industries Association (EIA) that defines the interface between data terminal equipment (DTE) and data circuit-terminating equipment (DCE), using serial binary data interchange.

electromagnetic interference. A disturbance in the transmission of data on a network resulting from the magnetism created by a current of electricity.

EIA unit. A unit of measure equal to 4.45 cm (1.75 in.).

EMC. Electromagnetic compatibility.

emulation. (1) The use of a data processing system to imitate another data processing system, so that the imitating system accepts the same data, executes the same programs, and achieves the same results as the imitated system. Emulation is usually achieved by means of hardware or firmware. (T) (2) The use of programming techniques and special machine features to permit a computing system to execute programs written for another system.

enable. To make functional.

enabled. (1) On a LAN, pertaining to an adapter or device that is active, operational, and able to receive frames from the network. (2) Pertaining to the state in which a transmission control unit or an audio response unit can accept incoming calls on a line.

end node. (1) In SNA, a node in a APPN network that can be a source or target node but does not provide any routing or session services to any other node. (2) A type 2.1 node that does not provide any intermediate routing or session services to any other node.

equipment rack. Synonym for *rack*.

error. A discrepancy between a computed, observed, or measured value or condition and the true, specified, or theoretically correct value or condition. (I) (A) Contrast with *failure* and *fault*.

explorer frame. See *explorer packet*.

explorer packet. A packet, generated by the source host that traverses the entire token-ring network gathering information on the possible paths the host might use.

F

F. Fahrenheit.

FC. See *frame control character*.

FCS. See *frame check sequence*.

FDX. See *full-duplex*.

feature. (1) A part of an IBM product that can be ordered separately by the customer. (2) See *switch feature*.

fiber. (1) Dielectric material that guides light; waveguide (see *multimode* and *single-mode optical fiber*). See *optical fiber*.

fiber optics. The branch of optical technology concerned with the transmission of radiant power through fibers made of transparent materials such as glass, fused silica, and plastic. (E)

Note: Telecommunication applications of fiber optics use optical fibers. Either a single discrete fiber or a nonspatially aligned fiber bundle can be used for each information channel. Such fibers are often called optical fibers to differentiate them from fibers used in noncommunication applications.

field. On a data medium or a storage, a specified area used for a particular class of data; for example, a group of character positions used to enter or display wage rates on a screen. (T)

file. A named set of records stored or processed as a unit. (T)

file name. (1) A name assigned or declared for a file. (2) The name used by a program to identify a file.

File Transfer Protocol (FTP). The Internet protocol (and program) used to transfer files between hosts. It is an application layer protocol in TCP/IP that uses Telnet and TCP protocols to transfer bulk-data files between machines or hosts.

filter. A device or program that separates data, signals, or material in accordance with specified criteria. (A)

flow control. In SNA, the process of managing the rate at which data traffic passes between components of the network. The purpose of flow control is to optimize the flow rate of message units with minimum congestion in the network, that is, to neither overflow the buffers at the receiver or at intermediate routing nodes, nor leave the receiver waiting for more message units.

frame. (1) In Open Systems Interconnection architecture, a data structure pertaining to a particular area of knowledge and consisting of slots that can accept the values of specific attributes and from which inferences can be drawn by appropriate procedural attachments. Synonymous with *schema*. (T) (2) A data structure that consists of fields, predetermined by a protocol, for the transmission of user data and control data. The composition of a frame, especially the number and types of fields, may vary according to the type of protocol. Synonymous with *transmission frame*. (T) (3) The unit of transmission in some local area networks, including the IBM Token-Ring Network; it includes delimiters, control characters, information, and checking characters. (4) In SDLC, the vehicle for every command, every response, and all information that is transmitted using SDLC procedures. (5) A packet that is transmitted over a serial line or LANs. See also *packet*.

frame check sequence. (1) A character determined by the data present within the transmission frame and appended to the transmission frame to allow detection of transmission errors. (T) (2) A field immediately preceding the closing flag sequence of a frame that contains a bit sequence checked by the receiver to detect transmission errors.

frame control character. A data control character that defines the type of transmission frame and certain control functions.

full-duplex. Synonym for *duplex*.

G

gateway. (1) A functional unit that interconnects two computer networks with different network architectures. A gateway connects networks or systems of different architectures. A bridge interconnects networks or systems with the same or similar architectures. (T) (2) A computer that attaches two or more networks and routes data packets to their destination through those networks. Contrast with *bridge* and *router*. (3) The original Internet term for router or IP router.

group. (1) A set of related records that have the same value for a particular field in all records. (2) A collection of users who can share access authorities for protected resources. (3) A list of names that are known together by a single name.

H

half-duplex. In data communication, pertaining to transmission in only one direction at a time. Contrast with *duplex*.

hardware. All or part of the physical components of an information processing system, such as computers or peripheral devices. (T) (A)

HDX. See *half-duplex*.

header. (1) System-defined control information that precedes user data. (2) The portion of a message that contains control information for the message such as one or more destination fields, name of the originating station, input sequence number, character string indicating the type of message, and priority level for the message.

hello. An internet protocol used by a group of cooperative, trusting routers to allow them to discover minimal delay routes.

host. (1) In Internet terminology, an end system. (2) In interpretive execution mode, the real machine as opposed to the virtual or interpreted machine (the guest).

host system. (1) A data processing system used to prepare programs and operating environments for use on another computer or controller. (2) The data processing system to which a network is connected and with which the system can communicate. (3) The controlling or highest-level system in a data communication configuration.

hr. Hour, 60 minutes.

Hz. A unit of frequency equal to one cycle per second.

I

IBM Token-Ring Network. A baseband local area network with a ring topology that passes tokens from Token-Ring adapter to Token-Ring adapter.

IEC. International Electrotechnical Commission

IEEE. Institute of Electrical and Electronics Engineers.

in. Inch, inches.

inactive. (1) Not operational. (2) Pertaining to a node or device not connected or not available for connection to another node or device. (3) Pertaining to a station that is only repeating frames or tokens, or both.

initialization. (1) The operations required for setting a device to a starting state, before the use of a data medium, or before implementation of a process. (T) (2) Preparation of a system, device, or program for operation. (3) To set counters, switches, addresses, latches, or storage contents to 0 or to other starting values at the beginning of, or at the prescribed points in, a computer program or process.

insert. To make an attaching device an active part of a LAN.

interface. (1) A shared boundary between two functional units, defined by functional characteristics, signal characteristics, or other characteristics, as appropriate. The concept includes the specification of the connection of two devices having different functions. (T) (2) Hardware, software, or both, that links systems, programs, or devices.

International Organization for Standardization. An organization of national standards bodies from various countries established to promote development of standards to facilitate international exchange of goods and services, and develop cooperation in intellectual, scientific, technological, and economic activity.

Internet Protocol. (1) A protocol that routes data through a network or interconnected networks. IP acts as an interface between the higher logical layers and the physical network. However, this protocol does not provide error recovery, flow control, or guarantee the reliability of the physical network. IP is a connectionless protocol. (2) A protocol used to route data from its source to its destination in an Internet environment.

IP. See *Internet Protocol*.

IP address. A 32-bit address assigned to devices or hosts in an IP internet that maps to a physical address. The IP address is composed of a network and host portion.

ISO. See *International Organization for Standardization*.

J

jack. A connecting device to which a wire or wires of a circuit can be attached and that is arranged for insertion of a plug.

jumper cable. Synonym for *patch cable*.

K

KB. (1) Kilobyte. (2) For processor storage and real and virtual memory, 1024 bytes. (3) For disk storage capacity and transmission rates, 1000 bytes.

Kb. Kilobit, 1000 bits.

Kcal. Kilocalorie, 1000 calories.

Kg. Kilogram, 1000 grams.

KVA. Kilovolt-ampere, 1000 volt-amperes.

KW. Kilowatt, 1000 watts.

L

LAN. See *local area network*

LAN segment. (1) Any portion of a LAN (for example, a single bus or ring) that can operate independently but is connected to other parts of the establishment network via bridges. (2) An entire ring or bus network without bridges. See *cable segment*, *ring segment*.

LAN Segment Number. The identifier that uniquely distinguishes a LAN segment in a multi-segment LAN.

latency. The time interval between the instant at which an instruction control unit initiates a call for data and the instant at which the actual transfer of data begins. Synonymous with *waiting time*. (T) See also *ring latency*.

lb. Pound, pounds.

LBP. Logical bridge port.

link connection. (1) All physical components and protocol machines that lie between the communicating link stations of a link. (2) The physical equipment providing two-way communication between one link station and one or more other link stations; for example, a telecommunication line and data circuit-terminating equipment (DCE). Synonymous with *data circuit*. (3) In SNA, the physical equipment providing two-way communication and error correction and detection between one link station and one or more other link stations.

link-attached. Pertaining to devices that are physically connected by a telecommunication line. Synonymous with *remote*.

LLC. See *logical link control*.

lobe. (1) In a star/ring network configuration, two pairs of conductors that provide separate send and receive paths between a wiring concentrator and a network

port, such as a wall outlet. (2) In the IBM Token-Ring Network, the section of cable that attaches a device to an access unit. The cable can consist of several segments.

local. Pertaining to a device accessed directly without use of a telecommunication line. Synonym for *channel-attached*. Contrast with *remote*.

local area network. (1) Physical network technology that transfers data at high speed over short distances. (2) A network in which a set of devices are connected to one another for communication and that can be connected to a larger network. See also *token-ring* and *Ethernet*. (3) A computer network located on a user's premises within a limited geographical area. Communication within a local area network is not subject to external regulations; however, communication across the LAN boundary may be subject to some form of regulation. (T) Contrast with *wide area network (WAN)*.

local directory database. That set of resources (LUs) in the network known at a particular node. The resources included are all those in the node's domain as well as any cache entries.

log. (1) To record; for example, to log all messages on the system printer. (2) A record of events that have occurred.

logical link control. (1) The data link control (DLC) LAN sublayer that provides two types of (DLC) operation. The first type is connectionless service, which allows information to be sent and received without establishing a link. The LLC sublayer does not perform error recovery or flow control for connectionless service. The second type is connection-oriented service, which requires the establishment of a link prior to the exchange of information. Connection-oriented service provides sequenced information transfer, flow control, and error recovery. (2) A sublayer of the OSI link layer that defines formats and protocols for exchanging frames between LLC sublayers attached to a local area network. It has provisions that ensure that error-free, nonduplicated, properly ordered frames are delivered to the appropriate data-link user. See also *bridge* and *medium access control (MAC)*.

logical link control protocol. In a local area network, the protocol that governs the exchange of transmission frames between data stations independently of how the transmission medium is shared. (T) The LLC protocol was developed by the IEEE 802 committee and is common to all LAN standards.

logical link control protocol data unit. A unit of information exchanged between link stations in different nodes. The LLC protocol data unit contains a destination service access point (DSAP) address, a

source service access point (SSAP), a control field, and user data. See *logical link control (LLC)*.

logical link control sublayer. One of two sublayers of the ISO Open Systems Interconnection data link layer (which corresponds to the SNA data link control layer), proposed for LANs by the IEEE Project 802 Committee on Local Area Networks and the European Computer Manufacturers Association (ECMA). It includes those functions unique to the particular link control procedures that are associated with the attached node and are independent of the medium; this allows different logical link protocols to coexist on the same network without interfering with each other. The LLC sublayer uses services provided by the medium access control (MAC) sublayer and provides services to the network layer.

LSB. Least significant bit.

M

mA. Milliampere, .001 amperes.

MAC. See *medium access control*.

management information base. A collection of objects that can be accessed by means of a network management protocol.

management station. The system responsible for managing all, or a portion of, a network. The management station talks to network management agents that reside in the managed node by means of a network management protocol such as Simple Network Management Protocol (SNMP). Synonymous with *network management station (NMS)*.

MB. (1) Megabyte (2) For processor storage and real and virtual memory, 1 048 576 bytes. (3) For disk storage capacity and transmission rates, 1 000 000 bytes.

Mb. Megabit. One million bits.

Mbps. One million bits per second.

medium access control. (1) The sublayer of the data link control layer that supports media-dependent functions and uses the services of the physical layer to provide services to the logical link control sublayer. The MAC sublayer includes the medium-access port. See *logical link control*. (2) For local area networks, the method of determining which device has access to the transmission medium at any time.

medium access control frame. In the IBM Token-Ring Network: (1) An address resolution request frame that has the unique part of a destination address and an "all rings" address. A sender issues this request to determine the ring where the destination station is

located and whether the node is active. (2) Response from an active destination node to the requesting source node, providing the source node with the complete address and ring number of the destination node.

medium access control procedure. In a local area network, the part of the protocol that governs access to the transmission medium independently of the physical characteristics of the medium, but takes into account the topological aspects of the network, in order to enable the exchange of data between data stations.

medium access control protocol. (1) In a local area network, the protocol that governs access to the transmission medium, taking into account the topological aspects of the network, in order to enable the exchange of data between data stations. (T) See also *logical link control protocol*. (2) The LAN protocol sublayer of data link control (DLC) protocol that includes functions for adapter address recognition, copying of message units from the physical network, and message unit format recognition, error detection, and routing within the processor.

medium access control segment. An individual LAN communicating through the medium access control layer within this network.

medium access control service data unit. In a medium access control frame, the logical link control protocol data unit (LPDU) and the routing information field (if the destination station is located on a different ring).

medium access control sublayer. In a local area network, the part of the data link layer that applies a medium access method. The MAC sublayer supports topology-dependent functions and uses the services of the physical layer to provide services to the logical link control sublayer. (T)

medium access control subvector. A group of related fields within a medium access control (MAC) major vector.

medium access control vector. The medium access control frame information field.

memory. All of the addressable storage space in a processing unit and other internal storages that is used to execute instructions. (T)

MIB. (1) Management information base. (2) MIB module.

microcode. (1) One or more microinstructions. (2) A code, representing the instructions of an instruction set,

that is implemented in a part of storage that is not program-addressable. (3) To design, write, and also test one or more microinstructions.

Note: The term microcode represents microinstructions used in a product as an alternative to hard-wired circuitry to implement functions of a processor or other system component. The term microprogram means a dynamic arrangement of one or more groups of microinstruction for execution to perform a certain function.

mm. Millimeter, millimeters.

modem (modulator/demodulator). (1) A functional unit that modulates and demodulates signals. One of the functions of a modem is to enable digital data to be transmitted over analog transmission facilities. (T) (A) (2) A device that converts digital data from a computer to an analog signal that can be transmitted in a telecommunication line, and converts the analog signal received to data for the computer.

monitor. (1) A device that observes and records selected activities within a data processing system for analysis. Possible uses are to indicate significant departure from the norm, or to determine levels of utilization of particular functional units. (T) (2) Software or hardware that observes, supervises, controls, or verifies operations of a system. (A) (3) In a token-ring network, the function required to initiate the transmission of a token on the ring and to provide soft-error recovery in case of lost tokens, circulating frames, or other difficulties. The capability is present in all ring stations.

MS. Management services.

MSAU. Multistation access unit.

MSDU. See *medium access control services data unit*.

MSB. Most significant bit.

multicast. (1) Transmission of the same data to a selected group of destinations. (T) (2) A special form of broadcast where copies of the packet are delivered to only a subset of all possible destinations. Contrast with *broadcast*.

multimode optical fiber. A graded-index or step-index optical fiber that allows more than one bound mode to propagate. (E) Contrast with *single-mode optical fiber*.

multistation access unit. In the IBM Token-Ring Network, a wiring concentrator that can connect up to eight lobes to a ring.

N

NetView. A host-based IBM licensed program that provides communication network management (CNM) or communications and systems management (C&SM) services.

network. (1) An arrangement of nodes and connecting branches. (T) (2) A configuration of data processing devices and software connected for information interchange. (3) A signal path connecting input/output devices to a system. A network can consist of multiple LAN segments connected together with bridging products. See ring (network). (4) The interconnection of two or more subnets.

network administrator. A person who manages the use and maintenance of a network.

network congestion. An undesirable overload condition caused by traffic in excess of what a network can handle.

network identifier. A 1- to 8-byte customer-selected name or an 8-byte IBM-registered name that uniquely identifies a specific subnetwork.

network management. The process of planning, organizing, and controlling a communications-oriented system.

network management station. The system responsible for managing a network or a portion of a network. The NMS talks to network management agents, that reside in the managed nodes, by means of a network management protocol. See also *agent*.

network manager. A program or group of programs that is used to monitor, manage, and diagnose the problems of a network.

network operator. (1) A person or program responsible for controlling the operation of all or part of a network. (2) In a multiple-domain network, a person or program responsible for controlling all domains.

network wiring closet. See *wiring closet*.

NIC. Network Information Center.

NMS. See *network management station*.

node. (1) In a network, a point at which one or more functional units connect channels or data circuits. (I) (2) In network topology, the point at an end of a branch. (T) (3) The representation of a state or an event by means of a point on a diagram. (A) (4) In a tree structure, a point at which subordinate items of data originate. (A) (5) An end point of a link or a junction common to two or more links in a network.

Nodes can be processors, communication controllers, cluster controllers, or terminals. Nodes can vary in routing and other functional capabilities.

NVRAM. Nonvolatile random access memory.

O

offline. (1) Pertaining to the operation of a functional unit that takes place either independently of, or in parallel with, the main operation of a computer. (T) (2) Neither controlled by, nor communicating with, a computer. Contrast with *online*.

online. (1) Pertaining to the operation of a functional unit when under the direct control of the computer. (T) (2) Pertaining to a user's ability to interact with a computer. (A) (3) Pertaining to a user's access to a computer via a terminal. (A) (4) Controlled by, or communicating with, a computer. Contrast with *offline*.

open. (1) To make an adapter ready for use. (2) A break in an electrical circuit. (3) To prepare a file for processing.

operating system. Software that controls the execution of programs and that may provide services such as resource allocation, scheduling, input/output control, and data management. Although operating systems are predominantly software, partial hardware implementations are possible. (T)

operation. (1) A defined action, namely, the act of obtaining a result from one or more operands in accordance with a rule that completely specifies the result for any permissible combination of operands. (A) (2) A program step undertaken or executed by a computer; for example, addition, multiplication, extraction, comparison, shift, transfer. The operation is usually specified by the operator part of an instruction. (A) (3) An action performed on one or more data items, such as adding, multiplying, comparing, or moving.

optical cable. A fiber, multiple fibers, or a fiber bundle in a structure built to meet optical, mechanical, and environmental specifications. (E)

optical fiber. Any filament made of dielectric materials that guides light, regardless of its ability to send signals. (E) See also *fiber optics*.

option. (1) A specification in a statement that can be used to influence the execution of the statement. (2) A hardware or software function that can be selected or enabled as part of a configuration process. (3) A piece of hardware (such as a network adapter) that can be installed in a device to modify or enhance device function.

OS. See *operating system*.

P

packet. (1) In data communication, a sequence of binary digits, including data and control signals, that is transmitted and switched as a composite whole. (I)
(2) Synonymous with *data frame*. Contrast with *frame*.

packet internet groper. A program used in TCP/IP networks to test the ability to reach destinations by sending the destinations an Internet Control Message Protocol (ICMP) echo request and waiting for a reply. The term, PING, is used as a verb.

panel. A formatted display of information that appears on a display screen.

parallel. (1) Pertaining to a process in which all events occur within the same interval of time, each handled by a separate but similar functional unit; for example, the parallel transmission of the bits of a computer word along the lines of an internal bus. (T)
(2) Pertaining to concurrent or simultaneous operation of two or more devices or to concurrent performance of two or more activities in a single device. (A)
(3) Pertaining to concurrent or simultaneous occurrence of two or more related activities in multiple devices or channels. (4) Pertaining to the simultaneity of two or more processes. (5) Pertaining to the simultaneous processing of the individual parts of a whole, such as the bits of a character and the characters of a word, using separate facilities for the various parts. (A)
(6) Contrast with *serial*.

parallel bridge. One of the two or more bridges that connect the same two LAN segments in a network.

parameter. (1) A variable that is given a constant value for a specified application and that may denote the application. (I) (A) (2) An item in a menu or for which the user specifies a value or for which the system provides a value when the menu is interpreted.
(3) Data passed between programs or procedures.

parity. (1) A transmission error-checking scheme in which an extra bit is added to some unit of data, usually a byte, in order to make the total number of one bits even or odd. For the AEA feature, odd, even, mark, space, or no-parity coding is supported. No-parity means that no parity bit is sent or expected. Mark and space mean that the parity position is always set to one or zero, respectively, and that received parity is not checked. (2) The state of being either even-numbered or odd-numbered.

parity (even). A condition when the sum of all of the digits in an array of binary digits is even.

parity (odd). A condition when the sum of all of the digits in an array of binary digits is odd.

password. In computer security, a string of characters known to the computer system and a user, who must specify it to gain full or limited access to a system and to the data stored within it.

patch cable. A length of cable with data connectors at both ends that is normally used to interconnect two sections of building cable at a patch panel or to connect a product to the building cable. Synonymous with *jumper cable*.

patch panel. An organized concentration of cable terminations, usually mounted in a flat panel, that facilitates the interconnection of communication cables.

path. (1) In a network, any route between any two nodes. A path may include more than one branch. (T) (2) The route traversed by the information exchanged between two attaching devices in a network. (3) The series of transport network components (path control and data link control) that are traversed by the information exchanged between two network accessible units (NAUs). A path consists of a virtual route and its route extension, if any.

path control. The function that routes message units between network accessible units in the network and provides the paths between them. It converts the basic information units (BIUs) from transmission control (possibly segmenting them) into path information units (PIUs) and exchanges basic transmission units containing one or more PIUs with data link control. Path control differs by node type: some nodes (APPN nodes, for example) use locally generated addresses or session identifiers for routing, and others (subarea nodes) use network addresses for routing.

path cost. A value, maintained by each IBM bridge program that uses the automatic single-route bridge function, that indicates to the automatic single-route bridge function the relative length of the path between the root bridge and a designated or standby bridge.

PC. (1) See *path control*. (2) See *personal computer*.

personal computer. (1) A microcomputer primarily intended for stand-alone use by an individual. (T)
(2) A desk-top, floor-standing, or portable microcomputer that usually consists of a system unit, a display monitor, a keyboard, one or more diskette drives, internal fixed-disk storage, and an optional printer. PCs are designed primarily to give independent computing power to a single user and are inexpensively priced for purchase by individuals or small businesses.

physical. (1) Pertaining to actual implementation or location as opposed to conceptual content or meaning.

(A) (2) Pertaining to the representation and storage of data on a medium such as magnetic disk, or to a description of data that depends on physical factors such as length of data elements, records, or pointers. (A) (3) Contrast with *logical*. (A)

physical circuit. A circuit established without multiplexing. See also *data circuit*. Contrast with *virtual circuit*.

PING. See *packet internet groper*.

plug. (1) A connector designed to insert into a receptacle or socket. (2) To insert a connector into a receptacle or socket.

pointer. (1) An identifier that indicates the location of an item of data. (A) (2) A data element that indicates the location of another data element. (T) (3) A physical or symbolic identifier of a unique target.

port. (1) An access point for data entry or exit. (2) A connector on a device to which cables for other devices such as display stations and printers are attached. Synonymous with *socket*. (3) The representation of a physical connection to the link hardware. A port is sometimes referred to as an adapter, however, there can be more than one port on an adapter. A single DLC process can control one or more ports. (4) An abstraction used by transport protocols to distinguish among multiple destinations within a host machine.

port number. The identification of an application entity to the transport service in IP.

POST. See *power-on self-test*.

power-on self-test. A series of diagnostic tests that are run automatically by a device when the power is switched on.

primary path. The channel an operation first uses.

problem determination. The process of determining the source of a problem; for example, a program component, a machine failure, telecommunication facilities, user or contractor-installed programs or equipment, an environment failure such as a power loss, or user error.

processor. In a computer, a functional unit that interprets and executes instructions. A processor consists of at least an instruction control unit and an arithmetic and logic unit. (T)

protocol. (1) A set of semantic and syntactic rules that determines the behavior of functional units in achieving communication. (I) (2) In Open Systems Interconnection architecture, a set of semantic and syntactic rules that determine the behavior of entities in

the same layer in performing communication functions. (T) (3) In SNA, the meanings of, and the sequencing rules for, requests and responses used for managing the network, transferring data, and synchronizing the states of network components.

Q

queue. A list constructed and maintained so that the next data element to be retrieved is the one stored first. (T)

R

rack. A free-standing framework that holds equipment.

rack inventory chart. An IBM Token-Ring Network planning chart indicating the location of the components installed in an equipment rack.

reduced instruction-set computer. A computer that uses a small simplified set of frequently used instructions for rapid execution.

remote. Pertaining to a system, program, or device that is accessed through a telecommunication line. Contrast with *local*. Synonym for *link-attached*.

remove. (1) To take an attaching device off a network. (2) To stop an adapter from participating in data passing on a network.

Request for Comments. Documents that describe the Internet suite of protocols and related experiments. All Internet standards are written as RFCs.

reset. On a virtual circuit, re-initialization of data flow control. At reset, all data in transit are eliminated.

RFC. See *Request for Comments*.

ring. (1) Two or more stations in which information is passed sequentially between active stations, each station in turn examining or copying the information, finally returning it to the originating station. (2) See also *ring network*.

ring attaching device. In a ring network, any device equipped with an adapter that is physically attached to the ring.

ring latency. In a token-ring network, the time, measured in bit times at the data transmission rate, required for a signal to propagate once around the ring. Ring latency includes the signal propagation delay through the ring medium, including drop cables, plus the sum of propagation delays through each data station connected to the token-ring network. (T)

ring network. (1) A network configuration in which devices are connected by unidirectional transmission links to form a closed path. (2) A network in which every node has exactly two branches connected to it and in which there are exactly two paths between any two nodes. (T) See also *star/ring network*, *token-ring network*.

ring segment. A ring segment is any section of a ring that can be isolated (by unplugging connectors) from the rest of the ring. A segment can consist of a single lobe, the cable between access units, or a combination of cables, lobes, and/or access units. See *cable segment*, *LAN segment*.

ring station. The functions necessary for connecting to the local area network and for operating with the token-ring protocols. These include token handling, transferring copied frames from the ring to the using node's storage, maintaining error counters, observing Medium Access Control (MAC) sublayer protocols (for address acquisition, error reporting, or other duties), and (in the full-function native mode) directing frames to the correct Data Link Control link station. A ring station is an instance of a MAC sublayer in a node attached to a ring.

RISC. See *reduced instruction-set computer*.

root bridge. In a LAN containing IBM bridges that use automatic single-route broadcast, the bridge that sends the "hello" message on the network every 2 seconds. Automatic single-route broadcast uses the message to detect when bridges enter and leave the network, and to change single-route broadcast parameters accordingly. See also *designated bridge*, *standby bridge*.

route. (1) The path that network traffic uses to get from source to destination. (2) An ordered sequence of nodes and transmission groups (TGs) that represent a path from an origin node to a destination node traversed by the traffic exchanged between them.

route bridge. A function of an IBM bridge program that allows two bridge computers to use a telecommunications link to connect two LANs. Each bridge computer is connected directly to one of the LANs, and the telecommunication link connects the two bridge computers.

router. (1) A computer that determines that path of network traffic flow. The path selection is made from several paths based on information obtained from specific protocols, algorithms that attempt to identify the shortest or best path, and other criteria such as metrics or protocol-specific destination addresses. (2) An attaching device that connects two LAN segments, which use similar or different architectures, at the reference model network layer. Contrast with *bridge*

and *gateway*. (3) In OSI terminology, a router is a network layer intermediate system.

routing. (1) The assignment of the path by which a message is to reach its destination. (2) In SNA, the forwarding of a message unit along a particular path through a network, as determined by parameters carried in the message unit, such as the destination network address in a transmission header.

RSA. Remote systems access.

Rx. Receive.

S

schema. Synonym for *frame*. (T)

scroll. To move a display image vertically or horizontally to view data that otherwise cannot be observed within the boundaries of the display screen. See also *page (2)*.

segment. (1) In the IBM Token-Ring Network, a section of cable between components or devices. A segment can consist of a single patch cable, several patch cables that are connected, or a combination of building cable and patch cables that are connected. (2) The unit of transfer between TCP functions in different machines. Each segment contains control and data fields whereby the current byte stream position and actual data bytes are identified along with a checksum to validate received data. (3) In an OS/2 program, a variable-length area of contiguous storage addresses not exceeding 64 KB. See also *data segment*, *cable segment*, *LAN segment*, *ring segment*.

select. The process of choosing a single symbol or menu item by placing the cursor on it and clicking the mouse button. To select multiple symbols simultaneously, press and hold the Shift key down while clicking on the symbols you want to select.

serial. (1) Pertaining to a process in which all events occur one after the other; for example, serial transmission of the bits of a character according to V24 CCITT protocol. (T) (2) Pertaining to the sequential or consecutive occurrence of two or more related activities in a single device or channel. (A) (3) Pertaining to the sequential processing of the individual parts of a whole, such as the bits of a character or the characters of a word, using the same facilities for successive parts. (A) (4) Contrast with *parallel*.

serial port. On personal computers, a port used to attach devices such as display devices, letter-quality printers, modems, plotters, and pointing devices such as light pens and mice; it transmits data 1 bit at a time. Contrast with *parallel port*.

server. (1) A functional unit that provides shared services to workstations over a network; for example, a file server, a print server, a mail server. (T) (2) In a network, a data station that provides facilities to other stations; for example, a file server, a print server, a mail server. (A) (3) A class of adapter in a network node that performs local processing and does not have any physical connections to other devices (as do port adapters and trunk adapters). (4) A device, program, or code module on a network dedicated to providing a specific service to a network.

session. (1) In network architecture, for the purpose of data communication between functional units, all the activities which take place during the establishment, maintenance, and release of the connection. (T) (2) A logical connection between two network accessible units (NAUs) that can be activated, tailored to provide various protocols, and deactivated, as requested. Each session is uniquely identified in a transmission header (TH) accompanying any transmissions exchanged during the session. (3) The period of time during which a user of a terminal can communicate with an interactive system, usually, elapsed time between logon and logoff.

Simple Network Management Protocol. (1) An IP network management protocol that is used to monitor routers and attached networks. (2) A TCP/IP-based protocol for exchanging network management information and outlining the structure for communications among network devices. SNMP is an application layer protocol. Information on devices managed is defined and stored in the application's Management Information Base (MIB).

single-mode optical fiber. An optical fiber in which only the lowest-order bound mode (which can consist of a pair of orthogonally polarized fields) can propagate at the wavelength of interest. (E) Contrast with *multimode optical fiber*.

SNMP. See *Simple Network Management Protocol*.

SNMP agent. As defined in the SNMP architecture, an agent, or an SNMP server, is responsible for performing the network management functions requested by the network management stations.

soft error. (1) An error that occurs sporadically and that may not appear on successive attempts to read data. Synonymous with *transient error*. (T) (2) An intermittent error on a network that requires retransmission. Contrast with *hard error*.

Note: A soft error by itself does not affect overall reliability of a network, but reliability can be affected if the number of soft errors reaches the ring error limit.

source address. A field in the medium access control (MAC) frame that identifies the location from which information is sent. Contrast with *destination address*.

source routing. A method by which the sending station determines the route the frame will follow and includes the routing information with the frame. Bridges then read the routing information to determine if they should forward the frame. Also known as source-route bridging.

spanning tree. The method by which bridges automatically develop a routing table and update that table in response to changing topography to ensure that there is only one route between any two LANs in the bridged LAN. This method prevents packet looping, where a packet returns in a circuitous route back to the sending router.

SRB. Source-route bridging. See *source routing*.

SRS. Source-route switching. See *source routing*.

standby bridge. In a LAN using automatic single-route broadcast, a bridge that does not forward single-route broadcast frames. A standby bridge is a parallel bridge or is in a parallel path between two LAN segments. See also *designated bridge, root bridge*.

star. A wiring arrangement in which an individual cable runs from each work area to a concentration point.

star/ring network. A ring network with unidirectional transmission, laid out in such a way that several data stations are grouped and interconnected to the network by means of lobe attaching units. This configuration allows attachment and removal of data stations without disrupting network operations. (A)

station. (1) An input or output point of a system that uses telecommunication facilities; for example, one or more systems, computers, terminals, devices, and associated programs at a particular location that can send or receive data over a telecommunication line. (2) A location in a device at which an operation is performed; for example, a read station.

Store-and-Forward switching mode. In LAN switches, a switching architecture which requires that a whole frame must be received by a destination port before transmission out of the destination port can begin. Contrast with *Cut-Through switching mode*.

STP. Shielded twisted pair.

subnet. Shortened form of *subnetwork*. See *subnetwork*.

subnet mask. A bit template that identifies to the TCP/IP protocol code the bits of the host address that are to be used for routing for specific subnets.

subnetwork. Any group of nodes that have a set of common characteristics, such as the same network ID.

switch. On an adapter, a mechanism used to select a value for, enable, or disable a configurable option or feature.

system. In data processing, a collection of people, machines, and methods organized to accomplish a set of specific functions. (I) (A)

system configuration. A process that specifies the devices and programs that form a particular data processing system. an element of a network.

T

TCP. See *Transmission Control Protocol*.

TCP/IP. See *Transmission Control Protocol/Internet Protocol*.

telephone twisted pair. One or more twisted pairs of copper wire in the unshielded voice-grade cable commonly used to connect a telephone to its wall jack. Also referred to as *unshielded twisted pair* (UTP).

Telnet. In TCP/IP, an application protocol that allows a user at one site to access a remote system as if the user's display station were locally attached. Telnet uses the Transmission Control Protocol as the underlying protocol.

terminal. In data communication, a device, usually equipped with a keyboard and display device, capable of sending and receiving information.

terminal emulation. The capability of a microcomputer or personal computer to operate as if it were a particular type of terminal linked to a processing unit and to access data.

TFTP. Trivial File Transfer Protocol. See *File Transfer Protocol*.

threshold. (1) A level, point, or value above which something is true or will take place and below which it is not true or will not take place. (2) In IBM bridge programs, a value set for the maximum number of frames that are not forwarded across a bridge due to errors, before a *threshold exceeded* occurrence is counted and indicated to network management programs. (3) An initial value from which a counter is decremented to zero, or a value to which a counter is incremented or decremented from an initial value. When the counter reaches zero or the threshold value, a decision is made and/or an event occurs.

throughput. (1) A measure of the amount of work performed by a computer system over a given period of

time, for example, number of jobs per day. (I) (A) (2) A measure of the amount of information transmitted over a network in a given period of time. For example, a network's data transfer rate is usually measured in bits per second.

TIA. Telecommunications Industries Association.

time-out. (1) An event that occurs at the end of a predetermined period of time that began at the occurrence of another specified event. (I) (2) A time interval allotted for certain operations to occur: for example, response to polling or addressing before system operation is interrupted and restarted. (3) A parameter related to an enforced event designed to occur at the conclusion of a predetermined elapsed time. A time-out condition can be canceled by the receipt of an appropriate time-out cancellation signal.

token. (1) In a local area network, the symbol of authority passed successively from one data station to another to indicate the station temporarily in control of the transmission medium. Each data station has an opportunity to acquire and use the token to control the medium. A token is a particular message or bit pattern that signifies permission to transmit. (T) (2) A sequence of bits passed from one device to another along the token ring. When the token has data appended to it, it becomes a frame.

token passing. In a token-ring network, the process by which a node captures a token; inserts a message, addresses, and control information; changes the bit pattern of the token to the bit pattern of a frame; transmits the frame; removes the frame from the ring when it has made a complete circuit; generates another token; and transmits the token on the ring where it can be captured by the next node that is ready to transmit.

token-ring. (1) A network with a ring topology that passes tokens from one attaching device to another; for example, the IBM Token-Ring Network. See also *local area network (LAN)*. (2) A group of interconnected token-rings.

token-ring network. (1) A ring network that allows unidirectional data transmission between data stations, by a token passing procedure, such that the transmitted data return to the transmitting station. (T) (2) A network that uses a ring topology, in which tokens are passed in a sequence from node to node. A node that is ready to send can capture the token and insert data for transmission. (3) A group of interconnected token-rings.

topology. The physical or logical arrangement of nodes in a computer network. Examples are ring topology and bus topology.

trace. (1) A record of the execution of a computer program. It exhibits the sequences in which the instructions were executed. (A) (2) A record of the frames and bytes transmitted on a network.

transient error. (1) Synonym for *soft error*. (T) (2) An error that occurs once or at unpredictable intervals.

Transmission Control Protocol (TCP). (1) A communications protocol used in Internet and in any network that follows the U.S. Department of Defense standards for inter-network protocol. TCP provides a reliable host-to-host protocol between hosts in packet-switched communications networks and in interconnected systems of such networks. It assumes that the Internet protocol is the underlying protocol. (2) A transport protocol in the Internet suite of protocols that provides reliable, connection-oriented, full-duplex data stream service.

Transmission Control Protocol/Internet Protocol. (1) A set of protocols that allow cooperating computers to share resources across a heterogeneous network. (2) A set of communication protocols that support peer-to-peer connectivity functions for both local and wide area networks.

transmission frame. (1) In data transmission, data transported from one node to another in a particular format that can be recognized by the receiving node. In addition to a data or information field, a frame has some kind of delimiter that marks its beginning and end and usually control fields, address information that identifies the source and destination, and one or more check bits that allow the receiver to detect any errors that occur after the sender has transmitted the frame. (2) In synchronous data link control (SDLC), the vehicle for every command, every response, and all information that is transmitted using SDLC procedures. Each frame begins and ends with a flag. (3) In high level data link control (HDLC), the sequence of contiguous bits bracketed by and including opening and closing flag (01111110) sequences. (4) In a token-ring network, a bit pattern containing data that a station has inserted for transmission after capturing a token.

transmit. To send information from one place for reception elsewhere. (A)

transparency. See *transparent*.

transparent. (1) Pertaining to operations or data that are of no significance to the user. (2) In data transmission, pertaining to information not recognized by the receiving program or device as transmission control characters.

transparent bridging. A method for tying individual local area networks (LANs) together through the

medium access control (MAC) level. A transparent bridge keeps the tables that hold MAC addresses so that frames seen by the bridge can be forwarded to another LAN if the tables indicate to do so.

trap. A vital part of the Simple Network Management Protocol (SNMP). A trap is specified data that is sent by a managed node (agent function) to a management station to report an exception condition.

tree network. A network in which there is exactly one path between any two nodes. (T)

twisted pair. A transmission medium that consists of two insulated electrical conductors twisted together to reduce noise. (T)

U

UDP. See *User Datagram Protocol*.

UFC. Universal feature card.

UNIX operating system. An operating system developed by Bell Laboratories that features multiprogramming in a multiuser environment. The UNIX operating system was originally developed for use on minicomputers, but has been adapted for mainframes and microcomputers.

Note: The AIX operating system is IBM's implementation of the UNIX operating system.

unshielded twisted pair. See *telephone twisted pair*.

User Datagram Protocol. (1) In TCP/IP, a packet-level protocol built directly on the Internet Protocol layer. UDP is used for application-to-application programs between TCP/IP host systems. (2) A transport protocol in the Internet suite of protocols that provides unreliable, connectionless datagram service. (3) The Internet Protocol that enables an application programmer on one machine or process to send a datagram to an application program on another machine or process. UDP uses the internet protocol (IP) to deliver datagrams.

UTP. See *unshielded twisted pair*.

V

V. Volt, a unit of electrical potential.

variable. (1) In computer programming, a character or group of characters that refers to a value and, in the execution of a computer program, corresponds to an address. (2) A quantity that can assume any of a given set of values. (A) (3) In SNMP, a match of an object instance name with an associated value.

version. A separately licensed program, based on an existing licensed program, that usually has significant new code or new function.

virtual circuit. (1) A logical connection established between two DTEs. (2) In packet switching, the facilities provided by a network that give the appearance to the user of an actual connection. (T) See also *data circuit*. Contrast with *physical circuit*. (3) In a packet-switching data network, a logical end-to-end transmission channel—as opposed to a physical connection—that connects X.25 users. Virtual circuits allow physical transmission facilities to be shared by many users simultaneously. (4) Synonym for *virtual connection*.

virtual connection. (1) A connection between two nodes on the network that is established using the transport layer and that provides reliable data between nodes. (2) A logical connection established between two data terminal equipment (DTE) devices. Synonymous with *virtual circuit*.

virtual machine. (1) A virtual data processing system that appears to be at the exclusive disposal of a particular user, but whose functions are accomplished by sharing the resources of a real data processing system. (T) (2) A functional simulation of a computer and its associated devices. Each virtual machine is controlled by a suitable operating system; for example, the conversational monitor system. VM/370 controls concurrent execution of multiple virtual machines on a single System/370 computing system.

VM. See *virtual machine*.

W

waiting time. Synonym for *latency*.

WAN. See *wide area network*.

wide area network. (1) A network that provides communication services to a geographic area larger than that served by a local area network or a metropolitan area network, and that may use or provide public communication facilities. (T) (2) A data communications network designed to serve an area of hundreds or thousands of miles; for example, public and private packet-switching networks and national telephone networks. Contrast with *local area network (LAN)*.

wiring closet. A room that contains one or more distribution panels and equipment racks that are used to interconnect cables. Sometimes called a *network wiring closet* to distinguish it from a telephone wiring closet.

workstation. (1) A functional unit at which a user works. A workstation often has some processing capability. (T) (2) Personal desktop computer consisting of a monitor, keyboard, and central processing unit. Workstations can have voice/data application program software enabled by CallPath for Workstations.

write. To make a permanent or transient recording of data in a storage device or on a data medium. (I) (A)

Index

A

- adapter mode, port 3-27
- adaptive switching mode 3-26, 4-14
- Address Aging menu 3-28
- Addresses
 - aging 3-28
 - changing filters 3-42
 - IP, configuring 3-15
 - MAC address template C-1
 - Master Address Table, viewing 4-3
 - on Switch Information panel 3-11
 - trap receivers 3-20
- authentication failure traps 3-18
- auto-configuration, port 3-26

B

- BootP
 - IP addresses, and 3-15
 - procedure 6-5
 - sending PING 3-16
- buttons
 - reset 1-11
 - system request 1-11

C

- cables
 - description 2-2
 - STP 2-2
 - straight-through 2-2
 - UTP 2-2
- cabling
 - chart A-2
- capacity of the 8270-800 1-2
- Change LAN Segment Bridging Parameters panel 3-36
- changes, saving 3-7
- cold boot 5-1
- communication port 1-11
- Communities
 - creating 3-19
 - strings 3-19
- Community Strings panel 3-19
- configuration 3-1
- configuration loss 3-25, 3-27
- Configuration Menu 3-10
- configuration type, port 3-26
- Configure Filters panel 3-43
- Configure Port Security Mode panel 3-45
- configuring
 - address aging, port 3-28

- configuring (*continued*)
 - address table aging 3-29
 - address table aging, master 3-30
 - change LAN segment bridging parameters 3-36
 - console, the 3-53
 - domain names 3-14
 - domains 3-14
 - duplex mode 3-27
 - filters 3-43
 - IP addresses 3-15
 - LAN segment bridging parameters 3-35
 - MAC addresses template C-1
 - MAC filter 3-42
 - port path cost 3-23
 - port priority 3-23
 - port security 3-42
 - port security mode 3-45
 - serial link 3-54
 - source routing 3-33
 - source-route bridge manual Spanning Tree parameters 3-41
 - source-route bridge path cost 3-40
 - source-route bridge spanning tree
 - configuration 3-38
 - source-route bridging 3-34
 - source-route switching 3-31
 - spanning tree 3-21
 - Telnet sessions 3-55
 - the 8270 using SNMP 3-17
 - Token-Ring ports 3-25
 - TokenPipe 3-48
 - TokenProbe 3-46
 - trap receivers 3-20
- console
 - communication settings 3-1
 - connecting 3-1
 - starting a session 3-8
- Console Configuration menu 3-53
- Copyright panel 3-8
- cost, port 3-23
- cut-through switching mode 3-26, 4-14

D

- dedicated media 2-2
- default gateway 3-2, 3-16
- default settings 3-2—3-6
- diagnostic messages 1-10, 5-4
- Diagnostic Test Results panel 5-3
- dimensions 1-13
- display, status 1-10

- Domain Address Table panel 4-8
- Domain Configuration panel 3-13
- Domain Names panel 3-14
- Domain Route Descriptor Table panel 4-9
- Domain Statistics panel 4-10
- domains
 - address table 4-8
 - configuring 3-13
 - naming 3-14
 - route descriptors, viewing 4-9
 - statistics 4-10
 - transparent bridge spanning tree information 4-11
- downloading software 6-1
 - BootP 6-5
 - serial port 6-3
 - TFTP 6-3
- duplex mode, setting 3-26, 3-27

E

- EIA 232 port 1-11, 3-1

F

- features, IBM 8270-800 1-2
- fiber optic Token-Ring 1-11
- forward delay 3-3, 3-22
- frame length limit 2-2
- fuses 1-10

I

- internal port mapping D-1
- introduction to the 8270 1-1
- IP Configuration panel 3-15

L

- labels 1-6
- LAN Segment Bridging Parameters panel 3-35
- LEDs
 - ports, UFCs 1-12
 - status, power supply 1-8
 - status, processor card 1-9
 - status, UFCs 1-12
- link connection, port 3-26
- locator charts 2-11, A-23, A-24
- loops
 - spanning tree 3-21
 - spanning tree statistics 4-11

M

- MAC address 1-3, 4-3, 4-8, 4-17
- MAC address template C-1
- MAC filter 3-42

- MAC Filter & Port Security menu 3-42
- Main Menu 3-9
- managing the 8270 4-28
- Master Address Table Aging panel 3-30
- Master Address Table panel 4-3
- Master Route Descriptor Table panel 4-4
- menus
 - See also* panels
 - Address Aging 3-28
 - Console Configuration 3-53
 - MAC Filter & Port Security 3-42
 - SNMP Configuration 3-18
 - Source-Route Bridge Configuration 3-34
 - Status/Statistics Menu 4-1
 - System Request Menu 6-2
- Message Log Information panel 4-7
- messages, diagnostic 1-10
- MIBs (management information bases) 3-17
- modem, connecting 3-2
- modes, switching 3-26
 - duplex, setting 3-26
- Module Information panel 4-2
- module reset button 1-11
- monitoring panels
 - Domain Route Descriptor Table 4-9
 - Port N Address Table 4-17
- monitoring the 8270 4-1

N

- network management 3-17
- network management station 3-17
- nonvolatile RAM 5-2

O

- operating environment 1-13
- overview, functional 1-14

P

- panels
 - See also* menus
 - Change LAN Segment Bridging Parameters 3-36
 - Community Strings 3-19
 - Configure Filters 3-43
 - Configure Port Security Mode 3-45
 - Diagnostic Test Results 5-3
 - Domain Address Table 4-8
 - Domain Configuration 3-13
 - Domain Names 3-14
 - Domain Route Descriptor Table 4-9
 - Domain Statistics 4-10
 - IP Configuration 3-15
 - LAN Segment Bridging Parameters 3-35
 - LAN Segment Selection 4-26

panels (*continued*)

- Master Address Table 4-3
- Master Address Table Aging 3-30
- Master Route Descriptor Table 4-4
- Message Log Information 4-7
- Module Information 4-2
- Password 3-51
- Port Address Table Aging 3-29
- Port Configuration 3-25
- Port N Address Table 4-17
- Port N Filters 4-23
- Port N Route Descriptor Table 4-18
- Port N Statistics 4-19
- Port Priority And Port Path Cost 3-23
- Port Status 4-14
- Reset Switch/Diagnostics 5-4
- Reset/Diagnostics 5-2
- Serial Link Configuration 3-54
- Source-Route Bridge 4-24
- Source-Route Bridge (SRB) Manual Spanning Tree Parameters 3-41
- Source-Route Bridge (SRB) Path Cost 3-40
- Source-Route Bridge Spanning Tree Configuration 3-38
- Source-Route Bridging (SRB) Statistics 4-27
- Source-Route Configuration 3-33
- Spanning Tree 3-21
- Switch Statistics 4-5
- Switching Mode Threshold 3-49
- Telnet Configuration 3-55
- Telnet Sessions 3-56
- TokenPipe Configuration 3-48
- TokenPipe Status 4-16
- TokenProbe Configuration 3-46
- Transparent Bridge Spanning Tree Information 4-11
- Trap Receivers 3-20

Password panel 3-51

PINGing BootP 3-16

planning 2-1—2-11

- cables 2-2
- charts and worksheets 2-11
- distances between devices 2-2

port

- adapter mode 3-27
- address aging 3-28
- address table, viewing 4-17
- configuration 3-25
- cost 3-23
- duplex mode 3-27
- duplex mode, setting 3-26
- enabling and disabling 3-26
- filters, viewing 4-23
- link connection 3-26
- security mode 3-45
- speed 3-27
- statistics 4-19

port (*continued*)

- status, viewing 4-14
- switching mode 3-26
 - TokenPipe, configuring 3-48

Port Address Table Aging panel 3-29

Port Configuration panel 3-25

Port N Address Table panel 4-17

Port N Filters panel 4-23

Port N Route Descriptor Table panel 4-18

Port N Statistics panel 4-19

port path cost 3-23

port priority 3-23

Port Priority And Port Path Cost panel 3-23

port security 3-42

Port Status panel 4-14

ports, Token-Ring 1-11

power requirements 1-13

power supply

- faceplate 1-7
- LEDs 1-8
- module 1-7

processor card

- description 1-8

R

- RAM, nonvolatile 5-2
- Reset button 1-11
- Reset Switch/Diagnostics menu 5-4
- Reset/Diagnostics menu 5-2
- resetting the 8270 5-1
- route descriptor 4-4, 4-9, 4-18

S

- safety information xi, xix
- sample applications 2-4—2-8
- saving changes 3-7
- Serial Link Configuration panel 3-54
- shared media 2-2
- simple network management protocol
 - See SNMP
- sketching your network 2-1
- SNMP
 - communities 3-19
 - configuration 3-18
 - description 3-17
 - trap receivers 3-20
- SNMP Configuration menu 3-18
- Source-Route Bridge Configuration menu 3-34
- Source-Route Bridge Manual Spanning Tree Parameters panel 3-41
- Source-Route Bridge Path Cost panel 3-40
- Source-Route Bridge Spanning Tree Configuration panel 3-38

- Source-Route Bridge Spanning Tree Status panel 4-24
- Source-Route Bridge Statistics LAN Segment Selection panel 4-26
- source-route bridging 1-2, 2-8
- Source-Route Bridging Statistics panel 4-27
- Source-Route Configuration panel 3-33
- source-route switching 1-2, 2-8, 3-31
- spanning tree 2-9
 - defined 3-21
 - enabling and disabling 3-21
 - information panel 4-11
- Spanning Tree panel 3-21
- speed, port 3-27
- statistics 4-1
 - domain, viewing 4-10
 - port, viewing 4-19
 - switch, viewing 4-5
 - transparent bridge spanning tree, viewing 4-11
- status
 - display 1-10
 - system 4-1
- Status/Statistics Menu 4-1
- store-and-forward switching mode 3-26, 4-14
- STP cable 2-2
- straight-through cables
 - description 2-2
- switch 3-3
 - forward delay 3-22
 - Information panel 3-11
 - modes 4-14
 - priority 3-3
- Switch Information panel 3-11
- Switch Statistics panel 4-5
- Switching Mode Threshold panel 3-49
- System Request button 1-11
- System Request Menu 6-2

T

- Telnet Configuration panel 3-55
- Telnet Sessions panel 3-56
- threshold, switching mode 3-49
- TokenPipe
 - configuring 3-48
 - defined 1-3
 - status, viewing 4-16
- TokenPipe Configuration panel 3-48
- TokenPipe Status panel 4-16
- TokenProbe
 - configuring 3-46
 - defined 1-4
- TokenProbe Configuration panel 3-46
- Transparent Bridge Spanning Tree Information panel 4-11
- Trap Receivers panel 3-20

U

- UFC (universal feature card)
 - configuring 3-6
 - Module Information panel 4-2
 - types of 1-11
- updating microcode 6-1
- UTP cable 2-2

V

- virtual switch 1-2

W

- warm boot 5-1
- weight 1-13
- worksheets, filling out 2-11

Tell Us What You Think!

**8270 Models 600 and 800
Planning, Configuration, and Operation
First Edition
July 1998**

We hope you find this publication useful, readable, and technically accurate, but only you can tell us! Your comments and suggestions will help us improve our technical publications. Please take a few minutes to let us know what you think by completing this form. If you are in the U.S.A., you can mail this form postage free or fax it to us at 1-800-253-3520. Elsewhere, your local IBM branch office or representative will forward your comments or you may mail them directly to us.

Overall, how satisfied are you with the information in this book?	Satisfied	Dissatisfied
	<input type="checkbox"/>	<input type="checkbox"/>

How satisfied are you that the information in this book is:	Satisfied	Dissatisfied
Accurate	<input type="checkbox"/>	<input type="checkbox"/>
Complete	<input type="checkbox"/>	<input type="checkbox"/>
Easy to find	<input type="checkbox"/>	<input type="checkbox"/>
Easy to understand	<input type="checkbox"/>	<input type="checkbox"/>
Well organized	<input type="checkbox"/>	<input type="checkbox"/>
Applicable to your task	<input type="checkbox"/>	<input type="checkbox"/>

Specific comments or problems:

Please tell us how we can improve this book:

Thank you for your comments. If you would like a reply, provide the necessary information below.

Name

Address

Company or Organization

Phone No.

Tell Us What You Think!



Cut or Fold
Along Line

Fold and Tape

Please do not staple

Fold and Tape



NO POSTAGE
NECESSARY
IF MAILED IN THE
UNITED STATES

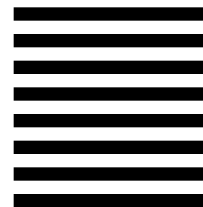

BUSINESS REPLY MAIL

FIRST-CLASS MAIL PERMIT NO. 40 ARMONK, NEW YORK

POSTAGE WILL BE PAID BY ADDRESSEE

Design & Information Development
Dept. CGF/Bldg. 656
International Business Machines Corporation
PO BOX 12195
RESEARCH TRIANGLE PARK NC 27709-9990



Fold and Tape

Please do not staple

Fold and Tape

Cut or Fold
Along Line



Printed in the United States of America
on recycled paper containing 10%
recovered post-consumer fiber.